

User Manual



Fun2Go 2



FunTrain 2



Combination Fun2Go 2 and FunTrain 2

Van Raam
Guldenweg 23
7051 HT Varsseveld, The Netherlands

☎ +31 (0)315 – 25 73 70

✉ info@vanraam.com

🌐 www.vanraam.com

Version 25.04



Table of contents

Manufacturer contact details	3
Conformity.....	3
Introduction.....	4
Item number	4
Indication.....	5
Intended usage	5
Safety measures.....	6
Adjusting the bicycle	10
Before the first use.....	13
Silent electrical system	18
Silent Electrical System options	29
Van Raam e-bike app.....	31
Accessories.....	32
Technical specifications	41
Maintenance and adjustments to be done by owner.....	42
Repairs and maintenance to be done by dealer	43
Disposal	49
Handover/sale to a new owner	49
Guarantee	49
Frame number.....	50
Maintenance recommendation	51
Service plan.....	53
Delivery and service form	55

Manufacturer contact details

Van Raam Mobility B.V.
Guldenweg 23
7051 HT Varsseveld, The Netherlands

☎ +31 (0)315 – 25 73 70

✉ info@vanraam.com

🌐 www.vanraam.com

Conformity

Europe (CE)

Van Raam Mobility B.V., as manufacturer, declares that the Fun2Go 2 / FunTrain 2, as described in this user manual, is manufactured in accordance with Regulation (EU) 2017/745, risk class 1. The Fun2Go 2 / FunTrain 2 supplied with the Silent electrical system also complies with Directive 2006/42/EC including the applicable parts of EMC Directive 2014/30/EU and the NEN-EN 15194:2017 Bicycles - Electric supporting bicycles - EPAC Bicycles - part 4.2 Electrical requirements. The signed declaration of conformity can be found on the Van Raam website.

UK (UKCA)

Van Raam Mobility B.V. as manufacturer declares that the Fun2Go 2 / FunTrain 2, as described in this user manual, is manufactured in accordance with the "Essential Requirements of Medical Devices Regulation 2002" (UK MDR 2002 Class 1 Medical Devices). The Fun2Go 2 / FunTrain 2 supplied with the Silent electrical system also complies with the "Machinery (Safety) Directive SI 2008/1597" including the applicable parts of "Electro Magnetic Compatibility Regulations SI 2016/1091" and the NEN-EN 15194:2017 Bicycles - Electric support bicycles - EPAC Bicycles - part 4.2 Electrical requirements. The Fun2Go 2 / FunTrain 2 is provided with UKCA label according to "EU Exit Regulations 2020/1478". The signed declaration of conformity can be found on the Van Raam website.

Introduction

We urge you to read this user manual thoroughly before using the bicycle. Always follow the instructions as outlined in the user manual and keep them safe. The most up-to-date version of the user manual can be found on the product page of the bicycle on the www.vanraam.com website.



READ CAREFULLY

For children and people with limited mental faculties, all safety and usage aspects of this user manual must be made understandable by a responsible, supervisory person.

Item number

Fun2Go item number: 387-

FunTrain item number: 389-

Delivery

The delivery should include the following:

- Tricycle with packaging
- User manual(s)
- Possible chargers (depending on options)
- (Spare) keys

Check the delivery immediately after receiving it. In case of damage or incomplete delivery we ask you to contact your dealer immediately. Upon delivery you should fill out the form "Form service, maintenance, modifications and warranty claims" in the back of this manual.

Indication

The Fun2Go 2 is widely used by institutions, homes, individuals and municipalities, and is aimed at people who are no longer able to ride on their own in traffic. The main rider of the bicycle must be able to control and operate the bicycle at all times. The passenger may have a disability, due to a very wide range of conditions. The Fun2Go 2 can be used by children or adults with neuromuscular disorders (such as cerebral palsy, muscular dystrophy). This also covers problems with coordination, balance disorders and a limited natural range of movement. As well as people with a visual impairment. The FunTrain 2 is an option that can be added to the Fun2Go 2 that allows 1 able-bodied person to cycle with 3 co-riders.

Intended usage

The tricycle has been designed for normal use on a flat, solid surface. In general, tricycle caution should always be observed when using the tricycle. Moreover, the safety instructions as described in this manual should be explicitly followed. Local traffic laws and regulations should also be observed.

The tricycle is meant for two persons, coupled to the FunTrain 2 it is meant for four persons. The driver should be independently mobile and may not have any serious visual or other impairment, which prevent responsible participation in traffic. The maximum user weight and basket load (to be found in the chapter '**Technical Specifications**') may not be exceeded.

The manufacturer is not responsible for any damage or injury caused as a result of or during the course of any other type of use.

Safety measures

- There should **always** be a supervising person as the main driver of the bike. This main driver is always responsible for the safe use of the bike.
- Ensure the tricycle is in good condition each time before using it. Check before **each** ride that the brakes are in order. Check the lighting and make sure there is enough tyre pressure.
- Regularly check if the wheels, the handlebars and the saddle are properly fixed and also whether all screw joints are tight.
- Only use the tricycle on a **solid and level surface**.
- It is not recommended to cycle on a slope steeper than 10%, this carries an increased risk.
- It is advised to **drive slowly on slopes**, especially when riding backwards. When braking while riding backwards, it is advised to use a dosed braking force. When doing so, avoid the bike losing contact with the road.
- In the case you stand still on a slope or ramp, proceed to drive off slowly. While driving off you can lean forwards to prevent the front wheel being lifted.
- Are you rolling backwards on a slope? Then brake densely to prevent the front wheel from losing contact with the road surface.
- Avoid riding on steep slopes when your bike is fitted with one of the following accessories on the rear of the bike: Walking Holder bracket, wheelchair holder, or loaded baskets. In these cases, the front wheel of your bike may lose contact with the road more easily.
- Make sure that wide trousers or loose hanging clothing don't get caught in the chain, spokes or pedals.
- Do not use a pressure washer or a steam cleaner for the cleaning of the tricycle.
- Block the tricycle to stop it from moving when you are getting on or off the tricycle. Do this by using the parking brake and holding the tricycle. See the chapter "Before the first use" for proper use of the parking brake.
- Always lock the tricycle when leaving it unattended.
- Make sure that you do not reach a dangerous speed when driving downhill and entering tunnels. Brake in time and bike at a moderate speed.
- In case of pregnancy, extra care is required owing to a higher risk of injury.
- Please note that brake discs can become hot during braking. Be careful not to touch the brake discs shortly after a bike ride.

- Do not leave the tricycle in direct sunlight: the temperature of some parts could exceed 41°C resulting in possible burns to the skin.
- If the bicycle has pedal assistance: practice using the starting aid and reverse function. When using the bicycle, make sure that the starting aid or reverse function is not activated unintentionally. For example, if the pedals are playfully turned backwards at a traffic light, the reverse function will be activated, and the bike will start to reverse. For more information, read the chapter "Electro System Silent" carefully.
- If a charger is supplied with the bicycle, please also read the section "Charger safety measures" in the "Electro System Silent" chapter.
- For safety reasons, the Fun2Go with pedal assistance is limited to a maximum of 20 km per hour.



Extra attention is essential if a child is using the tricycle!

- **Never** leave a child alone with the tricycle without supervision!
- **Always** have the child wear a tricycle helmet! Make sure the helmet fits correctly!



Extra attention is required if a child or adult with limited mental perception is using the bicycle.

Tips for safe cycling

Make sure you have adjusted the bike properly to the riders' measurements, after that you can use the bike safely and comfortably.



Riding a side-by-side tandem is a completely different experience than a bike with two wheels!

Key safety points for the main rider

- Cycle extremely carefully during the first ride.
- Practice steering around corners and braking in particular, as a side-by-side tandem can react the opposite way than you might expect.
- Keep your hands on the handlebars and feet on the pedals while riding.
- Test the handling of the side by side tandem at an appropriate speed on an uneven surface. This will help you learn to respond better to unexpected movements of the bike and handlebars while riding.
- Explore how the tilting motion of the side by side tandem responds to body posture. Hang towards the inner side of the turn. Make turns at an appropriate speed.
- Small obstacles should be ridden over at an appropriate speed.
- Always drive perpendicularly and at low speed off the curb or speed bump.
- Obstacles higher than five centimetres should be avoided.
- One of the brake levers operates the brake on the front wheel. Extra caution is required here, because the front wheel can lock if the brakes are pulled too strongly. Practise braking in a measured way.

Check before every ride

Contact your dealer and do not use the bike as soon as you notice any irregularities during the check!

- Check that the brakes are working correctly. The brakes should work, and you should feel pressure on the brake lever.
- Make sure there is enough air in the tires. The tires may be inflated to the maximum pressure indicated on the side of the tire. Tip for extra comfort: You do not have to inflate the front wheel to the maximum pressure, but make sure you always stay above the minimum specified pressure.
- Check that the lights are working correctly. See chapter "**Before the first use**" for the correct setting of the lights.
- Check that the seat and handlebars are properly secured. See chapter "**Adjusting the bicycle**" for the correct adjustment of the seat and handlebars.
- Make sure the battery is sufficiently charged (optional).

As with all mechanical parts, the bicycle is subject to wear and tear and high loads. If a component fails, it could result in very dangerous situations and lead to harm or injury to the user of the bicycle. Any cracks, scratches or change of colour in sections of a component that are subject to heavy loads is an indication that the component should be replaced.

Load

The maximum permissible load must not be exceeded. See the information in the table with technical data under the chapter "**Technical specifications**" in the user manual. The permissible load is understood to mean the total load, including the load in the basket and what is carried on the carrier rack.

Make sure that the permitted weight of the basket is not exceeded (**maximum 20 kg**). No people are allowed to be carried in the basket.

Damaged or worn parts

The replacement and repair of the parts (frame, front fork, lights, brakes, drive and handlebar) should **always** be carried out by a dealer. Otherwise, the warranty will be void and the user will themselves be liable for any damage.



Safety-related parts must **always** be replaced by new parts!

Adjusting the bicycle

Before using the bike, adjust it to the measurements of the main rider and co-rider. This is essential, especially for the seat and handlebars.



If it's not possible to adjust it optimally with the given instructions, please contact your dealer for a suitable workaround.

The brakes are correctly adjusted as standard and should only be checked and adjusted by the dealer during regular maintenance.



Make sure that fingers and other limbs do not get caught when adjusting the bicycle

Seat position

To adjust the seat position correctly, the main rider must place one foot on the pedal in the outermost position away from the co-rider. Adjust the position so that the leg is straight but still relaxed in this situation.

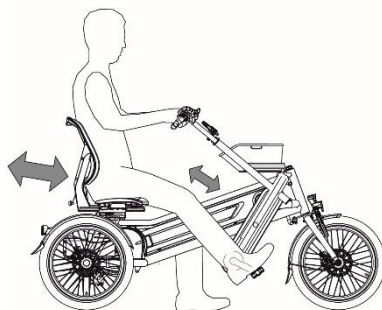

To adjust the seat:

1. Pull the lever [A] on the outer side of the seat outwards.
2. Slide the seat to the correct position, then release the lever.

Caution: Make sure the adjustment of the seat slides into the locking position. You might hear a click when this happens.

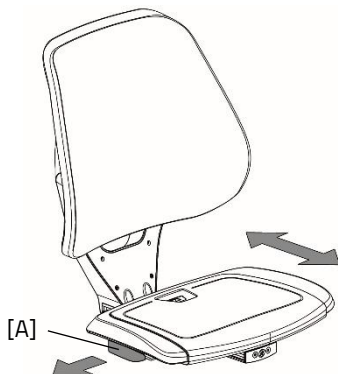

Seat depth

The seating area of the seat can be adjusted to tailor the seat to the user's comfort. In order to adjust the seat, follow these steps:

1. Remove the seat cushion [A] from the seat frame.
2. Now that the seat cushion has been removed, the seat frame can be adjusted in relation to the backrest. To do this, loosen the 4 socket head screws [B] a few turns.
3. Slide the seat frame forwards or backwards.
4. Tighten the 4 socket-head screws [B].
5. Place the seat cushion by first sliding the front edge over the seat frame. Then push the 4 snap covers into the holes.

Caution! Adjusting the seat depth affects the minimum and maximum inside leg length for the bike.

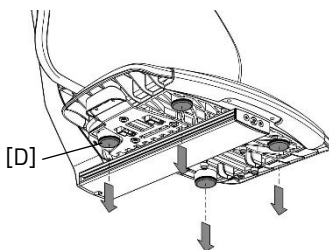
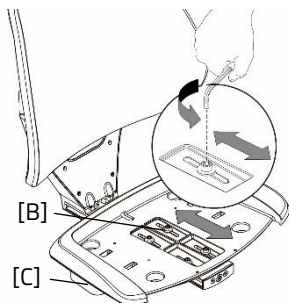
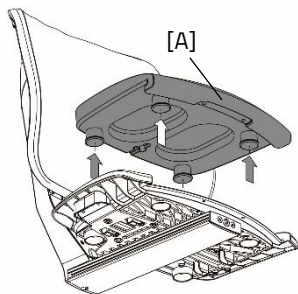

Handlebar height

The height of the handlebars influences riding comfort. This determines the pressure on the hands and the posture of the back. You determine the most comfortable position yourself in practice.

To adjust the handlebars:

1. Loosen the hex key [A] a few turns with an Allen key.
2. Slide the handlebar stem to the correct height and then tighten the hex key firmly again.

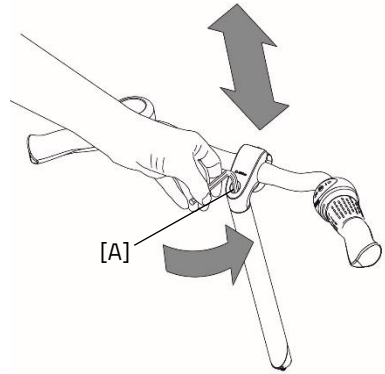

Do not pull out the handlebar stem **further** than the mark. Otherwise, the tube will not stick into the shaft deep enough and there is a risk of it breaking off, which can lead to serious injuries.



Handlebar position

You can angle the handlebars. This affects the posture of your arms. Decide for yourself in practice what is most comfortable.

To angle the handlebars:

1. Loosen the bolt [A] with a few turns with an Allen key.
2. Move the handlebars to the desired position and then firmly re-tighten the screw.

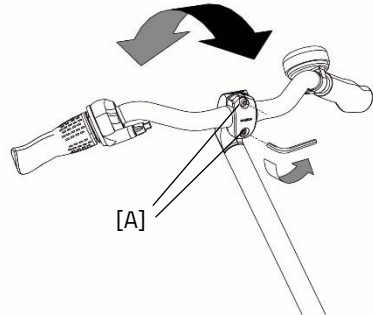

Before the first use

Parking brake (Fun2Go)

Always use the parking brake if you park the tricycle and leave it behind.

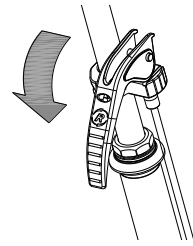

Block the tricycle with the hydro brake when passengers are getting on and off.

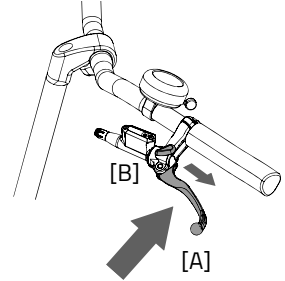

To operate the parking brake, squeeze the left brake [A] and secure the brake with the lever [B].



Always try to park the tricycle on a level surface. The tricycle may never be parked on a slope bigger than 6 degrees.

Parking brake (FunTrain)

When the FunTrain is parked separately from the Fun2Go, use the parking brake [A] of the FunTrain.

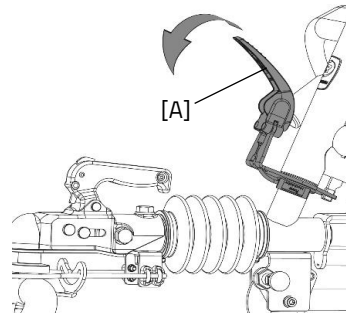

Lighting

Normally, the lighting on your bike can be operated manually and set to different modes. However, if your bike is equipped with the Silent Elektro system, your lighting will automatically turn off when the electric system is activated. The controls of both the manually operated and centrally operated lighting is explained below.

Manually operated headlight

The headlight has a button with three different modes: ON – ON [50%] – OFF

Adjust the angle of the headlight to its correct position, when the centre of the light beam is about 10 metres in front of the bicycle.

The headlight is powered by batteries. When the batteries are nearly empty, the LED light in the button of the headlight will turn red. Follow the steps to change the batteries of the headlight.

1. Open the headlight by pushing down the tab on the housing and simultaneously pulling the front of the light outward like shown.
2. Change the two alkaline batteries (2x AA).
3. Put the light back together by first pushing the top of the light back into the housing and then pushing the bottom of the light back over the tab of the housing.

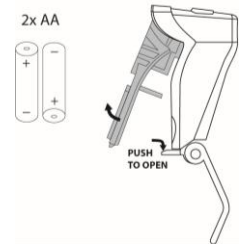
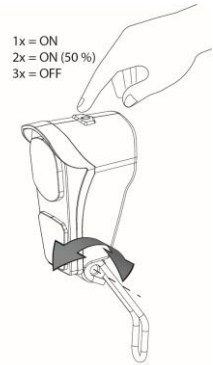

You can only operate the light while your bike is standing still to avoid dangerous situations and to avoid the chance of entrapment.

Manually operated rear light

The rear light can be switched on by using the ON / OFF button underneath.

The rear light works with batteries. When the battery is almost empty, a red LED lights up [B]. Follow the steps below to replace the batteries.

1. Use a flat object [C], such as a coin, to pry off the front of the lamp.
2. Remove the front cover [D] from the housing.
3. Replace the battery [E] at the back of the PCB [F].

Battery type: CR2032



Batteries pollute the environment. When disposing of them, please follow local regulations.

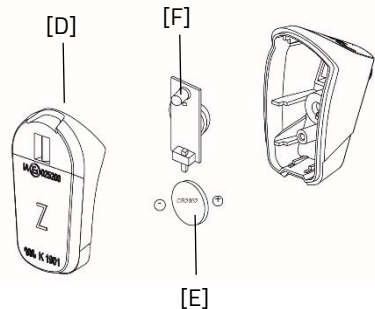
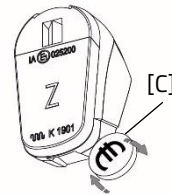
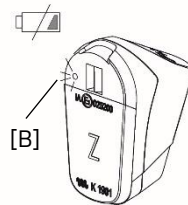
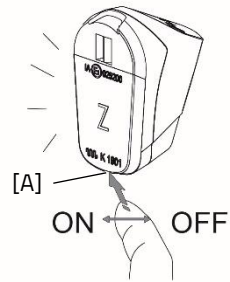

Centrally Operated Lighting

The bike has been equipped with centrally operated lighting, with the lighting being connected to the electric system.

The lighting will turn on automatically when the electric system is activated.

Adjust the angle of the headlight, so that the centre of the light beam is aimed about ten metres in front of the bike.

You can manually turn the lighting on and off by briefly pressing the bike light button on the display.

When the electric system is turned off, the lighting will turn off automatically.

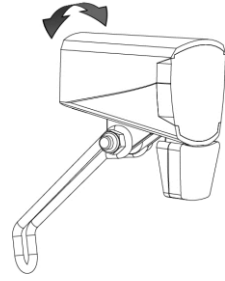

Make sure there is always a battery on the bike when you are cycling after dark!

Once the battery is nearly empty, the motor will no longer provide pedal support power assistance while cycling. The lighting will still be powered by leftover power.

Gears

Standard the tricycle has eight gears. The gears are used by turning the grip. **Do not use the pedals** when turning the grip.

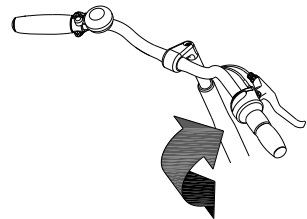

Couple the FunTrain

Follow these steps to attach the FunTrain to a Fun2Go with a ball coupling:

1. Lift the lever of the ball coupling [A] over the tow ball [B].
2. Hook the safety cable [C] behind the tow ball and into the bracket [D], as shown.
3. The ball coupling is securely attached to the tow ball when the indicator [E] is in the green area with the "OK" sign.
4. Make sure to fold up the support wheel after coupling. First, release the locking bolt [F] by pulling it out.
5. Finally, fold up the support wheel until the locking bolt clicks back into place with an audible sound.

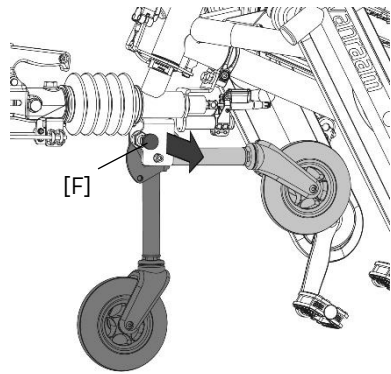
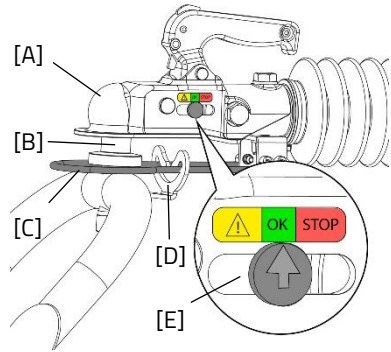

Uncouple the FunTrain

1. Unlock the locking bolt [F] of the support wheel by pulling it out.
2. Fold out the support wheel until the locking bolt [F] audibly clicks back into place.
3. Release the brake cable [C] so that it is no longer hooked under the bracket [D].
4. Lift the lever and then lift the ball coupling off the tow ball.



Beware that the safety cable comes off the towing ball together with the trailer coupler.

Silent electrical system

Item number: -2195

The Silent electric system is the pedal assist system of Van Raam and consists of 5 components: display, button unit, battery, motor and bottom bracket. How the first 3 parts are used is explained in this user manual.

Operation of the display

The display provides you with cycling information, which will be explained in more detail later. The display is mounted onto the handlebars by means of a bracket. The display cannot and does not have to be removed when leaving the bike.

(1) On/off

This button switches the electrical system on.

(2) Bicycle lights

The lights on the bicycle switch on automatically when the electrical system is switched on. By pressing this button briefly, the lights can be switched off (and on).

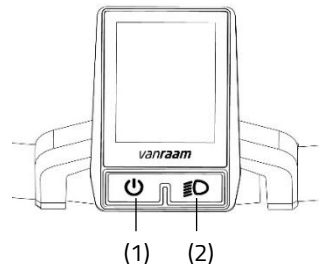

Operation of the button unit

The button unit is mounted next to the handlebar grip. You use the button unit to operate the electrical system.



The button unit can be mounted on the other side of the handlebars by your dealer.

(3) Mode

By pressing this button briefly, you can switch between the different Screen modes.

(4) Plus - Increase pedal support power assistance

(5) Minus - Reduce pedal support power assistance

(6) starting aid

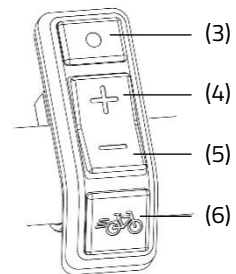

Information screen

After the electrical system is powered up, the information screen is displayed. This screen displays real-time cycling information.



The information screen will only work if you have switched on the electrical system.

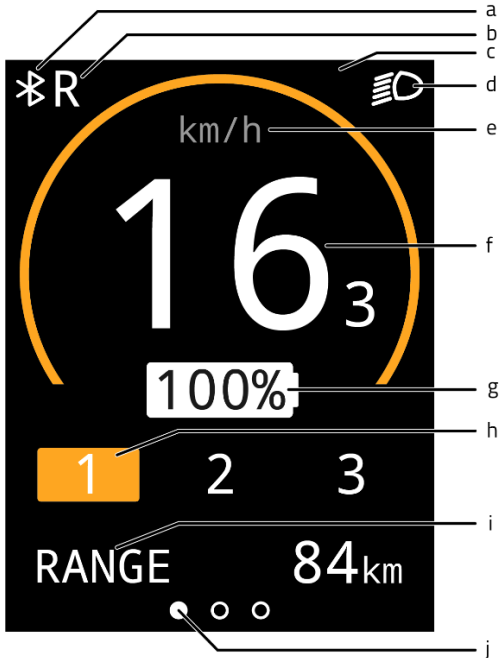

- (a) Bluetooth connection
- (b) Reverse function of (thumb) throttle activated
- (c) Notification field
- (d) Bicycle lights
- (e) Speed indicator
- (f) Speed
- (g) Battery charge percentage
- (h) Assistance mode
- (i) Screen modes
- (j) Screen mode orientation bar

Screen modes

The screen mode (i) can be set by using the mode button (3) You can switch between the following 3 screen modes while cycling.

1. Radius of action [RANGE] (default display)
This is the number of kilometres that can still be cycled with the remaining battery capacity in the active assistance mode.



The range is assistance mode dependent and is an estimate, so the actual range may differ from the estimate. The range is dependent on several factors. The range is influenced by factors such as battery capacity, level of assistance, tire pressure, riding speed, rider's weight, load, and environment.

2. Trip distance [TRIP]
This is the distance travelled since the trip odometer was last reset. By holding down the mode button for one second, the trip odometer can be reset to 0.
3. Total distance [TOTAL]
This is the total distance travelled by the bicycle when the electrical system has been switched on.



Settings screen





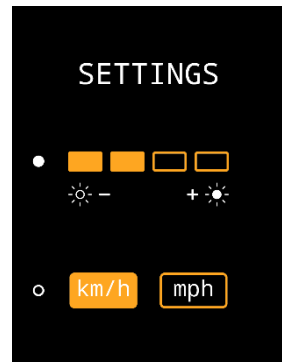

In the settings screen, the brightness of the display and the units of distance and speed can be changed.

To access the settings screen, the mode button (3) and the plus button (4) should be pressed down simultaneously for one second. Using the mode button (3), you can switch between the settings. The plus and minus buttons (4,5) are used to adjust the setting. To exit the setting screen, press and hold the mode button (3) for one second.



Notifications

Several symbols can be displayed in the information screen. The symbols are explained below. More information on the notifications can be found in the chapter **"Possible Faults"**.

	The bicycle lights are activated
	A Bluetooth connection is active
	No communications with the battery
	Reverse function of (thumb) throttle is activated
	The temperature of the controller is too high
	Voltage is too high
	Fault

Starting aid

With the starting aid, pedal assistance is activated up to a speed of 6 km/h, without having to pedal yourself. To do this, press and hold down the starting aid button (6). If the button is pressed again, the function is reactivated.

If you press the starting aid button while cycling, you will get a "boost". This boost will have the same maximum speed as the bike. The activated pedal assistance mode determines the degree of assistance of the starting aid and the "boost".

The starting aid button can be used for:

- Extra assistance when starting off (starting aid).
- Extra assistance when cycling uphill (boost).

Assistance settings

The pedal assistance level can be set using assistance settings 1, 2 and 3. The assistance settings can be changed while cycling.

1. Low level of assistance, maximum range.

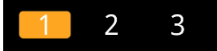

2. Average support, average range.



3. Maximum support, low range.

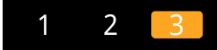

Reverse pedalling

The reverse function is activated by pedalling backwards from a stationary position. After a few turns of the wheel, the motor is activated, and the bicycle will reverse at the speed of 3 km/h for as long as it is pedalled backwards.



Do not let the electric motor's sudden behaviour take you by surprise. For example, if you wait at the traffic lights and pedal backwards just for fun, the reverse function will be activated, and the bike will start riding backwards!

Support modes

A support mode is a set of settings which sets the level of assistance. By loading a different mode, the level of assistance for all assistance modes can be adjusted. Modes can be changed by the dealer or through the Van Raam app.

Charging the battery

Follow these steps to remove and charge the bicycle battery:

1. Unlock the battery by turning the key a quarter turn.
2. Press the lock button.
3. Slide the battery a few centimetres from the sled.
4. You can now lift the battery off, using two hands if necessary.
5. Take the battery inside. **First**, insert the charger's connector into the battery's charging port.
6. **Then** plug the charger into the wall socket. A green LED on the battery will start blinking, and a red LED on the charger will light up to indicate that charging is in progress.



Caution! *If there is no proper contact between the battery and the charger, the green LED on the charger will light up (standby mode). This may indicate insufficient connection, so unplug the charger and clean the connector with a dry cloth.*

7. The charging time depends on the battery status. The charging time is approximately 2 hours for an 11.4 Ah/36 V battery and approximately 4.5 hours for a 23.5 Ah/36 V battery.
8. Once the battery is fully charged, the green LED will stay on continuously. **First**, unplug the charger from the wall socket.
9. **Then** remove the charger's connector from the battery. Place the battery back into the holder on the bike and lock it. The battery can also be charged directly in the holder if desired.

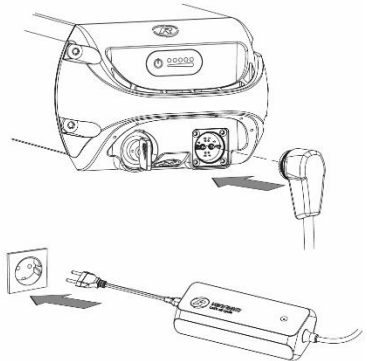
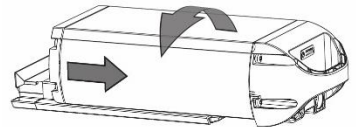
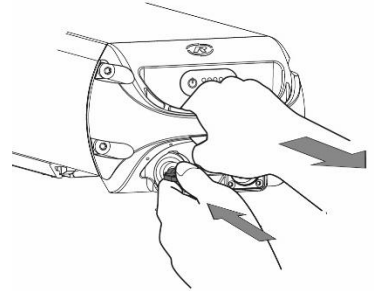
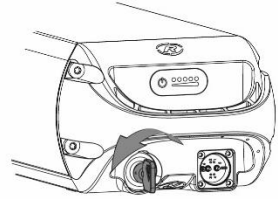

Charger indicator light

The status of the charger is indicated by the coloured indicator light.

- If the indicator light is green, the charger is in standby mode, or the battery is full.
- If the indicator light is red, then the charger is charging the battery.
- ⚠ If the indicator light is flashing red, the charger is in fault mode.

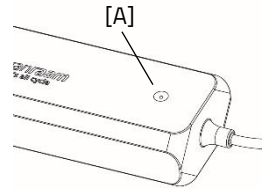

Caution! Unplug the charger from the power outlet.



Only use the charger when the ambient temperature is between 0 °C and 35 °C.



It is better for the battery to be charged periodically instead of waiting until it is completely empty.

Battery indicator lights

On the battery pack there is an LED indicator to check the battery charge status. The battery charge status can be read by briefly pressing the on/off button [A]. While the battery is being charged, the indicator shows the charging progress:

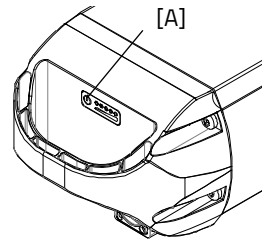

- The battery is fully charged. When the battery is used, the number of green lamps will decrease.
- If two green lamps are lit, the battery is 50% charged.
- If only the left LED remains green, the battery is almost empty and needs to be recharged or replaced with a charged battery.
- ⊙○○○○ If the left LED starts blinking green, the battery is empty and the motor will not support cycling for much longer. However, the switchable lighting will still work after that.



Never put the bike away with an empty battery.



Check the battery charge monthly during the winter and recharge it if fewer than three LEDs are lit.

Deep sleep battery mode

When the battery is almost empty and has not been used for a week, the battery will go into a "deep sleep mode". In this mode, the battery uses as little energy as possible, which extends the battery life.

When "deep sleep mode" is activated, the battery cannot be used. By pressing the on/off button [A] on the battery, the battery will be released from 'deep sleep mode' and can be used again. It is advisable to charge the battery before using it.

Charging and maintenance of the battery pack

Important safety warning:



Completely drain the battery during the first use. The battery will then make optimal use of its capacity. It is not necessary to drain the battery in one go; this can also be spread over several rides. After draining, fully charge the battery. The battery can then be used as needed.

- To ensure the battery's optimal condition and capacity, we recommend charging it indoors at room temperature.
- Never put the bicycle away with an empty battery. We recommend charging the battery as soon as possible when it is empty. The best storage charging level for the battery is when the charge display shows three to five LED lights.
- In winter, check the battery charge every other month, recharge it if less than three LEDs light up.
- Preferably store and use the battery between 5 °C and 20 °C, avoid higher and lower temperatures.
- Do not charge the battery in direct sunlight and make sure that the battery is not charged at a temperature lower than 5 °C.
- Only use the charger in dry indoor areas, the charger is not allowed to get wet.
- Only use the supplied Van Raam battery and charger.
- The housing of the battery and the charger must not be opened. In case of any problems, please consult your dealer.

- A Van Raam battery is not allowed nor is it possible to recondition the battery due to safety reasons and incorrect functioning of the electrical system.
- Do not drop the battery as this can cause external and internal damage.
- If the bicycle malfunctions, the battery must be disconnected from the bicycle.



Keep in mind that the bike provides less assistance at lower temperatures (0°C and below) and that the battery will drain more quickly. It also takes longer to charge at low temperatures.



Every battery drains over time. This process is called 'self-discharge'. A battery that is empty and not charged can undergo a deep discharge caused by self-discharge and become faulty as a result. The warranty is voided in the case of a deep discharge.



Keep in mind that every battery wears out over time. The wear and tear process of the battery is inevitable and depends on several factors such as use, the number of times to fully discharged and charged and the ambient temperature. Even if the battery is not used, its capacity will decrease. A worn-out battery can be used, but keep in mind that the range will be reduced.

Possible faults

- The system cannot be switched on:
 1. Check that the battery is attached properly.
 2. Check the status of the battery. If it is empty, charge the battery.
 3. If the above does not provide a solution, please contact your dealer.
- If a red LED flashes on the charger, unplug the charger from the power outlet and stop using the charger and battery. In this case, contact your dealer.

Faults table

Fault symbol/ code	Description	Consequence/ course of action
All assistance modes are flashing	Temperature controller too high	System does provide assistance, motor power is reduced.
Thermometer (symbol) + all assistance modes are flashing.	Temperature controller too high	System does not provide assistance, let the controller cool down.
Battery with cross (symbol) + all assistance modes are flashing	No communications with the battery	System does provide assistance. Contact your dealer.
Lightning bolt (symbol) + assistance settings are turned off	Voltage too high	System does not provide assistance, voltage drops automatically when cycling speed is slower than maximum assistance speed.
Exclamation mark (symbol) Exclamation mark (symbol)	Voltage too low	System does not provide assistance, check the connection between controller and battery. Check how full the battery is.
	Controller communication error	System does not provide assistance. Contact your dealer.
Active assistance mode is flashing	Electrical current too high	System does not provide assistance. Contact your dealer.
Active assistance mode is flashing	Motor sensor fault	System does provide assistance. Contact your dealer.
All assistance settings are turned off.	The battery is almost empty.	Charge the battery

Charging and maintenance of the battery pack

Important safety warning:

Charger safety precautions

- Only charge Van Raam Li-Ion batteries with the supplied charger. Only connect the charger to a suitable wall socket (220–240 Volt AC 50-60 Hz). When the charger is not in use, disconnect it from the power outlet and the power plug from the battery.
- The charger may only be used by persons who have read the information in this manual and are familiar with the correct use of the charger. Keep the charger out of reach of children; they should not play with the charger.
- The charger is designed for use in a dust-free, dry and ventilated environment. Do not expose the battery to water, heat sources and direct sunlight. Keep the charger clean and dry.
- Do not charge batteries that feel hot. The battery may only be charged in places where the temperature is no higher than room temperature. Stop charging if the battery gets hotter than ($> 40\text{ }^{\circ}\text{C}$).

Caution! The charger can become warm during charging $> 50\text{ }^{\circ}\text{C}$. First, carefully feel whether you can pick up the charger, this temperature can cause hypersensitivity or a startled reaction when it comes into contact with the skin.

- Do not use the charger if it is visibly damaged or modified. Do not repair the charger yourself! Please contact Van Raam. You are strictly prohibited from opening the charger yourself!
- Always keep an eye on the charger and battery while charging. When the battery is full, disconnect the power plug from power outlet and remove the power plug from the battery.

Silent Electrical System options

There are different options for the electrical system for each bicycle model.

External charging point

Item number: -2161

In order to make battery charging more accessible, the bicycle can be equipped with an external charging point in the backrest. The battery does not have to be removed from the bicycle to be charged. The external charging point is placed on the seat closest to the battery.



If it fails to charge, check whether the power plug of the external charging point is properly connected to the battery.

Spare battery

The bicycle can be equipped with a second battery. The second battery can be used when the first battery is empty. The batteries will need to be swapped.

Switchable battery pack

Item number: -2165

If you have two batteries, the bicycle can be equipped with the switchable battery pack option. Once the connected battery pack is empty, you can switch the system to the second battery pack by using the switch. This is located between the seats.

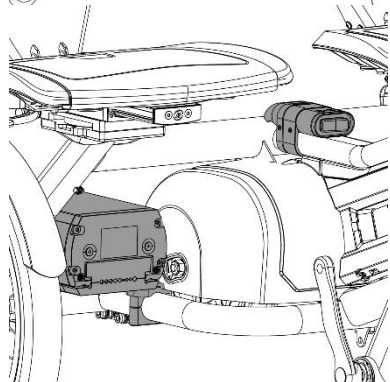
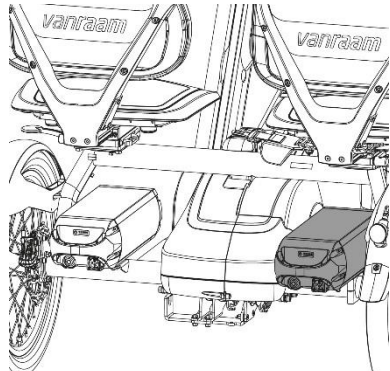
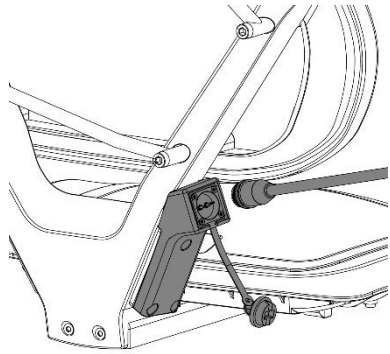

The switch has three settings:



- I: Left battery is connected to the system.
- O: No battery is connected to the system.
- II: Right battery is connected to the system.

Thumb throttle

Item number: -2183

The bicycle can be fitted with a thumb throttle. The thumb throttle is mounted next to the handlebar grip and can be operated by the thumb. When the throttle lever is operated, the bike will travel up to a maximum speed of 6 km/h without the need to pedal.

The switch on the throttle lever can be used to switch between forward and reverse gears. When the switch is set to '0', the bike will start riding forwards as soon as the throttle is operated, and when the switch is set to '1', the bike will start riding backwards at a maximum speed of 3 km/h.



When reverse mode is activated, it is not possible to change the support level. To change the support level, the switch must first be set to position '0'.

Direction indicator

Article number: -4170

The bike can be equipped with a direction indicator. To operate the direction indicator, press the switch [A] on the handlebar to the left or right.

The direction indicator is powered by the battery of the Silent electrical system.

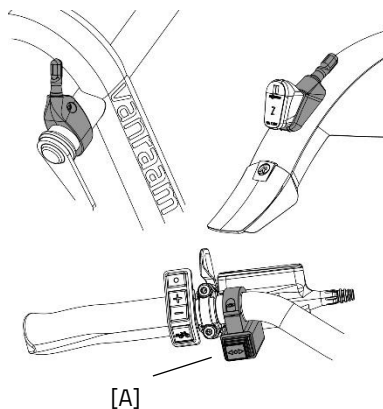

Please note that the turn signal can only be activated when the bicycle's lighting is turned on.

Van Raam e-bike app

The Van Raam bicycle app is a free smartphone app that you can use while cycling on your electric Van Raam bicycle.

The Van Raam e-bike app can be downloaded free of charge from the **Google Play Store** or **Apple App Store**.

Apple app store:



Google Play Store:



For more information about the Van Raam e-bike app, you can visit the Van Raam website: www.vanraam.com.

Accessories

Depending on the configuration of the bike, you can use the accessories listed below. Additional accessories are available through the dealer.

Gear shift options

Standard version (Shared gears)

Item number: -1150

In the standard version of the bicycle, the main rider and co-rider use the same 8-speed hub. This means that both users pedal at the same pedalling frequency. The handlebars of the main cyclist control the gears.

Both sides have a freewheel clutch and can power the bike separately.

Separate gears (2x 8v) (optional)

Item number: -1200

This gear shift option allows both the main rider and co-rider to select his/her own gears.

This gear shift option allows both the main rider and co-rider to select his/her own gears.

Both the main rider and co-rider have their own gear controls on the handlebars.

Both sides have a freewheel clutch and can power the bike separately from each other.

Switchable freewheel (optional)

Item number: -1500

The switchable freewheel allows the main cyclist to decide how the co-driver cycles along with them.

Caution! Never operate the switchable freewheel while cycling. Make sure the bike is completely stationary and only then use the gear lever.

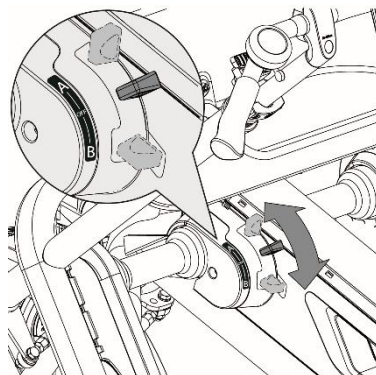

There are three different settings:

A: In this setting, the co-rider shares the gears with the main rider. Both pedal in the same gear which is controlled by the main cyclist.

Both sides have a freewheel clutch and can power the bike separately from each other.

OFF: In this setting, the pedals are completely released from the drive. This means that the co-rider can cycle freely without resistance and does not actively join in with cycling.

B: In this setting, the pedals rotate automatically when cycling. This forces the co-rider to cycle along and is unable to hold the pedals still. This is also known as the keep-on-peddalling/ therapy mode. (The pedalling frequency of mode B is comparable to gear 6)

Caution! Make sure that fingers and other limbs do not get caught when adjusting the switchable freewheel.

Caution! If you cycle backwards, the pedals of the co-rider also rotate.

Universal insertion adapter

Item number: -5100

The universal insertion adapter allows for different options to be mounted at the back of the bike and easily removed in case they are not needed.

The insertion adapter can be used for the following options: rear basket, rear luggage rack, wheelchair carrier, holder for foldable walker, and walker preparation.

Caution! The maximum allowable weight of these options is 20kg.

Caution! In case of a combined weight of 40 kg of luggage (both front and rear 20 kg), the maximum combined weight of two users must not exceed 220 kg.

Follow these steps to attach a rear option to the insertion adapter:

1. Loosen the hex bolts [A and B].
2. Slide the desired option into the two tubes.
3. Tighten the hex bolts [A and B] again.

The following options can be mounted simultaneously with any of the above options: anti-tipping wheels, stick holder, bumper, safety flag, and FunTrain towing ball.

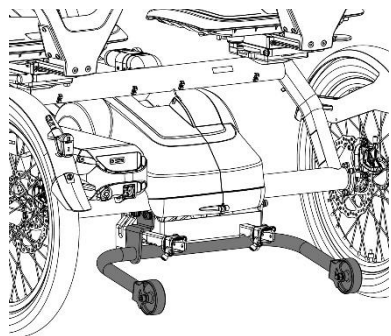
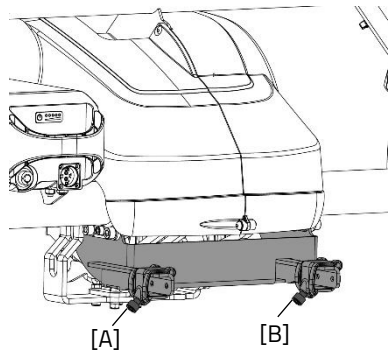

Stick holder

Item number: -0050

You can take two walking canes with you in the stick holder. Place the cane in the holder at the bottom [A] and then press the cane into the clips [B].

Always secure the canes(s) with the Velcro straps.

The stick holder can be mounted left or right. The depth of the stick holder can also be adjusted.

Please note. The depth setting of the stick holder can affect the adjustable range and swivel range of the seat.

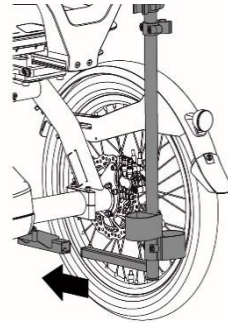
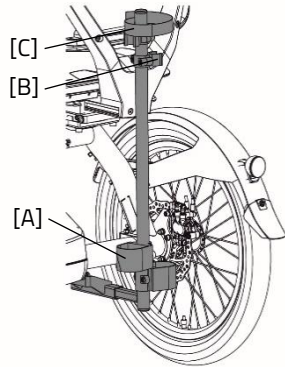

Crank shortener

Item number: -4092 / -4091

The crank shortener is fitted to the crank, as illustrated. The pedal can then be fitted into the crank shortener at two positions.

With the screw [A] the crank shortener should be aligned with the crank.

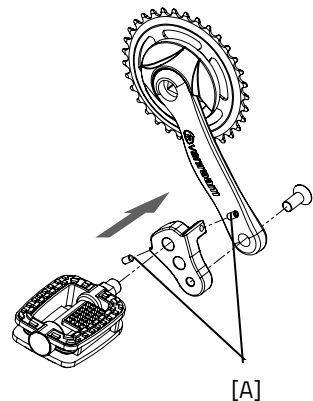

Foot support

Item number: -4232 / -4233 / -4234 / -4235

When using the foot support, you can fix your foot by sliding the two straps [A] in the quick releases [B].

The quick release can be unlocked by pulling the lip to the rear. Now the strap can be pulled out.

You can cut the straps to size. The strap should retain a length of at least five centimetres.

The position of the foot support on the pedal is adjustable in the longitudinal direction. This allows you to pedal with the ball of your foot for better thrust.

1. Slightly loosen the four nuts with a socket wrench.
2. Slide the plate included the foot support forwards or backwards into the desired position. Then tighten the nuts again.

The foot support is also adjustable in width. Only the outer half of the foot support can be extended.

1. Slightly loosen the two screws with an Allen key.
2. Slide the adjustable half of the foot support to the desired position. Then tighten the screws again.

With the axel pedal extender, the foot support can be extended further.

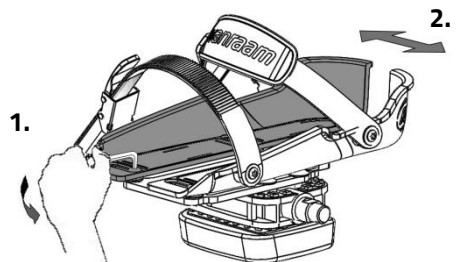
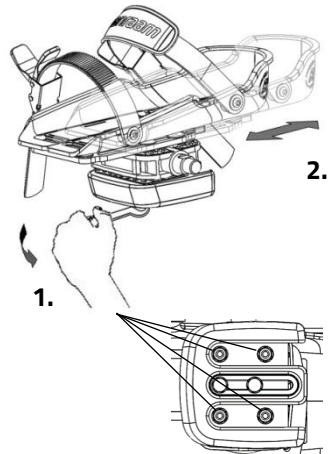
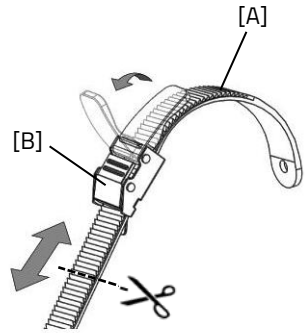



The small foot support (Fix20) is suitable for shoe sizes 22 up to size 36. The width of the range of this foot support is min. 6,5 cm to max. 9 cm. The large foot support (Fix25) is suitable from shoe size 37 up to size 48. The width of the range of this foot support is min. 8,5 cm to max. 13 cm.

The foot support returns to its neutral position when it is not used. The neutral position can be altered by shifting the balancing block.

1. Slightly loosen the two screws with a socket wrench.
2. Slide the balancing block to the desired position. Then tighten the screws again.

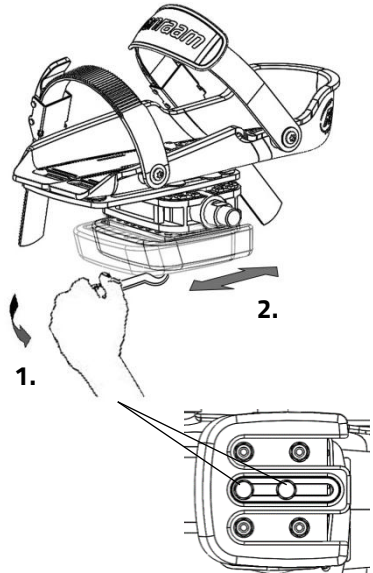

Lower Leg Fixation

Item number: -4245 / -4246 / -4247 / -4248

With the optional lower leg fixation, you can secure your lower leg. In order to set up the lower leg fixation:

1. Loosen the bolt [A] several turns using a nut spanner. Adjust the height of the lower leg fixation to the lower leg of the rider. Now tighten the bolt again.
2. Loosen the two nuts [B] several turns. The angle of the leg cup can now be adjusted. Rotate the leg cup in the correct position and retighten the nuts.
3. Use the Velcro to secure the lower leg.

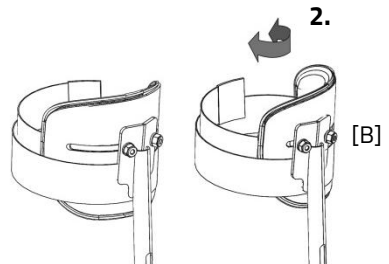
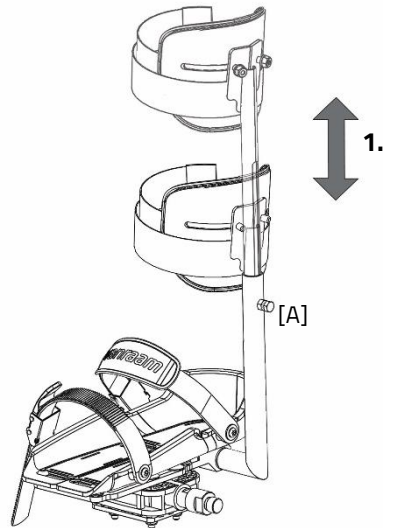

Rotatable seat

Item number: -0030

The rotatable seat can be used to be able to get on the bike from the side.

To rotate the seat, follow these steps:

1. Pull up the lever [A].
2. Rotate the seat. When the seat is rotated 90 degrees, the seat will lock into place.
3. Let the co-rider get on the bike.
4. Pull up the lever [A] and rotate the seat in the opposite direction until it locks into place.

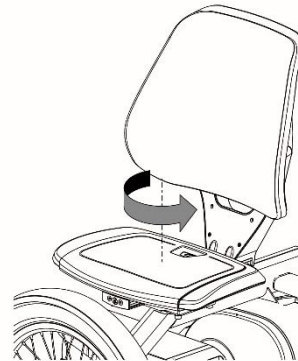
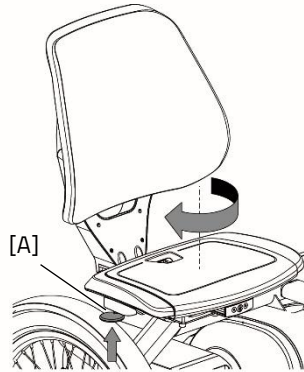

Hip belt co-rider

Item number: -0070

Wrap the hip belt around their body and click the buckle into the lock.

Caution! When retracting the hip belt, be sure to feed it back in a straight direction to prevent it from getting stuck.



Armrests (optional)

Item number: -0060

The armrests give the user extra comfort and safety.

To make it easier to get on the bicycle, you can fold up the armrests separately from each other.

While cycling, you can rest your arms on the armrests. Do **not** use the armrests as support when getting on and off.

Caution! The armrests must not be subjected to loads exceeding 50 kg.

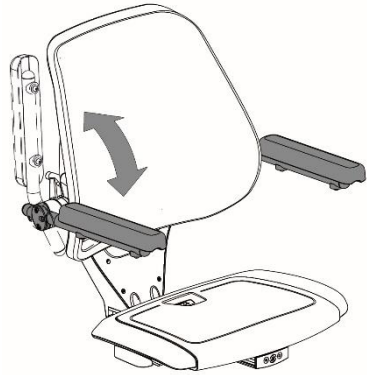

Footplate (optional)

Item number: -0025 / -0026

When cycling, you can rest your feet on the footplate.

A pneumatic spring locks the footplate into place under the seat. It can be unfolded manually by moving the footplate downwards at the height of the arrow. The same pneumatic spring keeps the footplate in the lowest position.

Caution! Only operate the footplate when the seat is stationary.

Caution! Do not use the footplate as a step.

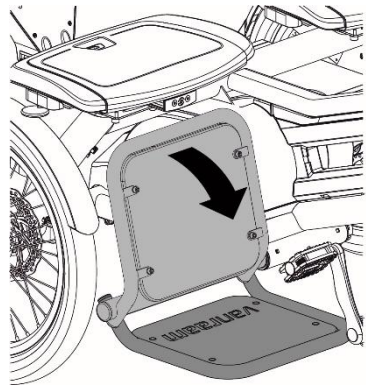

If the bicycle is riding backwards, the pedals will move and there is a risk that limbs will be trapped between the footplate and the pedals.

Technical specifications

	Fun2Go 2	FunTrain 2
Inside leg length (cm)	± 67-93	± 67-93
Length (cm)	199	193
Width (cm)	113 (incl. handlebars)	113 (incl. handlebars)
Height (cm)	109	109
Front wheel	20"	-
Rear wheel	20"	20"
Weight (kg) configuration without electrics	76	76
Total max. user weight (kg)	120 p.p.	120 p.p.
Max. load basket (kg)	20	20
Brakes, front	Mechanical disc brakes with parking brake function	-
Brakes, rear	Hydraulic disc brakes	Hydraulic disc brakes

Maintenance and adjustments to be done by owner

Below you can find the instructions for maintenance and adjustments that you can do yourself on a regular basis, which will keep your tricycle in top condition.

Cleaning

The frame of the tricycle can be cleaned with a damp cloth. For areas that are dirtier you can use a mild detergent.

The wheels can be cleaned with a moist brush with plastic hairs (not a wire brush!).

The grips, seats and upholstery of the seat and back can be cleaned with a damp cloth and mild detergent.



Do not use a pressure washer or a steam cleaner!

The right lubricant

The chain should be cleaned and maintained at regular intervals (every three months approximately). Only use special chain grease or Teflon spray. This is the only way to make sure that the chain will run smoothly, will stay water resistant and will not rust.

1. Wipe the chain with a cloth.
2. Treat it with grease or spray.
3. Remove any excess lubricant with a rag.

Other parts should **not** be treated with a lubricant.

Inspection of the tricycle

It is recommended that the tricycle has a yearly inspection carried out by the dealer to claim warranty. Please use the form "Form service, maintenance, modifications and warranty claims" in the back of this manual. After 200 kilometres or after a period of two months the tricycle should be inspected.

In the event of technical trouble or faults, the tricycle should be taken to the dealer for repairs **immediately**.

The replacing of safety-related components (especially frame, brakes, lighting, handlebars, front fork and actuation) should be performed by the dealer.

If you still decide you want to replace components yourself, you are responsible for damage or harm due to incorrectly fitted components. Only use **original** Van Raam spare parts, which you can buy at you dealer. If requested the dealer will make the necessary information on repair and maintenance available.

Repairs and maintenance to be done by dealer

Check the brakes, the rims, lighting, the chain tension and the spokes. Also check the tyre tread depth. This should be at least one millimetre. Worn out tyres or possible faulty parts should be replaced. Also check the parking brake. With the parking brake pulled up, the tricycle should not ride away with the cyclist.

Checking the rim

Due to the combined action of the brake and the rims, not only the brake lining but also the condition of the rim is important. For this reason, the rim should be checked at regular intervals, for example when you inflate the tyres. The presence of fine cracks in the spoke punches or deformation of the rim when there is higher air pressure, indicate more serious wear and tear. In that case the rim should be replaced, because it can lead to loss of brake function or even a crack in the rim, which can lead to all kinds of dangerous consequences.

Repairs, maintenance and modifications should only be performed with original Van Raam parts.

Removing the front cover

Follow these steps to remove the front cover of the chain guard:

1. Press the locking tabs [A] and [B] inward with a flathead screwdriver.
2. The front cover is now unlocked and can be rotated away.

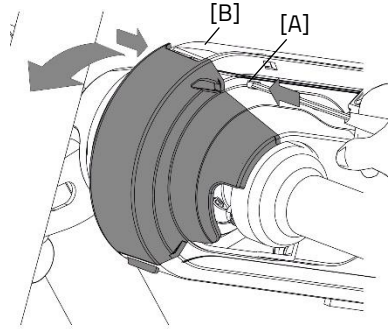

Removing the middle cover

To access the long chain, it is necessary to remove the left side of the middle cover. In most cases, the right side of the middle cover does not need to be removed as it is screwed onto the frame.

Follow these steps to remove the left side:

1. Use an Allen key to loosen screw [A].
2. Then, use a small flathead screwdriver to release the 6 locking tabs.
3. Carefully pull the chain guard away while releasing the locking tabs one by one, working from front to back.

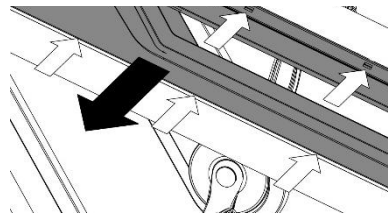
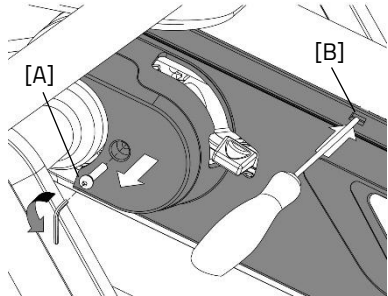

Removing Gear Hub Cover

To remove the hub cover, first the left side of the middle cover needs to be removed. Follow these steps to remove the hub cover:

1. Loosen the screws [A and B].
2. Then loosen the screws [C and D].
3. The chain guard is now loose and can be removed.

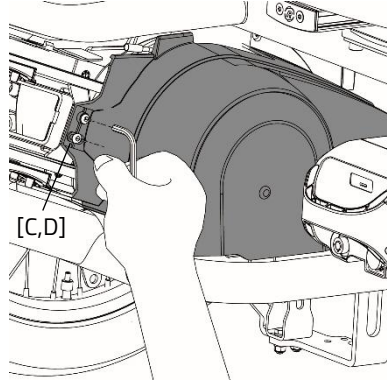
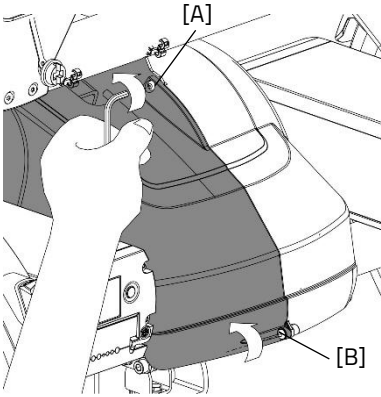

Removing Crank Cover

To access the crank chain covers, only the top of the chain guard needs to be removed. The bottom remains attached to the frame.

Follow these steps to remove the top:

1. Loosen screws [A and B] at the bottom of the crank chain guard.
2. Now the top of the crank chain guard [C] can be lifted off.

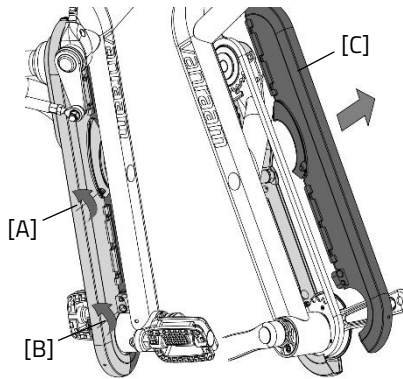

Adjusting the Chains

The bike is equipped with an automatic chain tension system, which helps to limit dealer maintenance. There are two chains that still need to be manually adjusted: the crank chain and the right middle chain combination with freehub function.

To tension the crank chain, follow these steps:

1. First loosen the Allen bolt [A].
2. Use the two holes [B] next to the Allen bolt to turn the eccentric bracket with a pin wrench [C].
3. Turn right to increase chain tension and left to decrease chain tension.
4. Once the correct chain tension is achieved, tighten the Allen bolt [A] again (12 Nm).

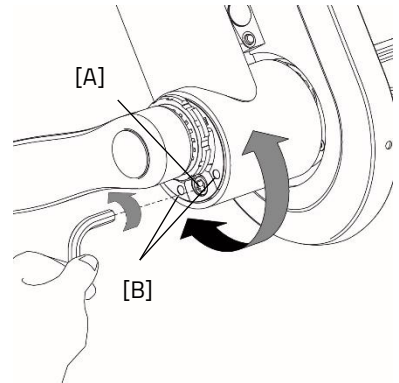

To turn the pin wrench on the eccentric bracket, make sure the pins of the wrench are not thicker than 4 mm.

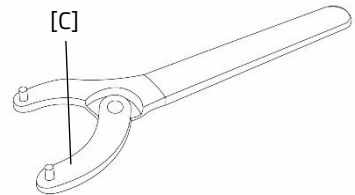

Automatic chain tensioning system

The bike is equipped with various automatic chain tensioning systems to minimize the chain adjustment work.

Long middle chain tensioner

The long middle chain has an automatic chain tensioner that ensures the chain always has the correct tension. It does not need to be adjusted. Please note that the chain tensioner cannot indicate when the chain is worn.

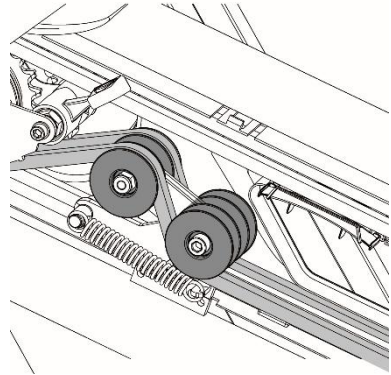

Gear hub and motor chain tensioner

The chains from the gear hub and motor to the rear axle are automatically tensioned. If the tensioning system can no longer tension the chain further, the fork must be adjusted.

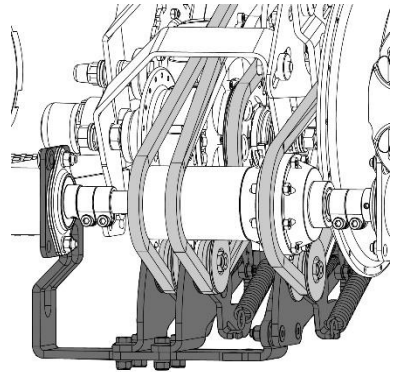

Adjusting chain tension for the through-axe variant

In the case of the gear hub with through-axe option, the long right chain line does not have an automatic tensioning system. It can be adjusted using a fork at the rear of the bike.

1. Loosen bolt [A].
2. Pull the fork backwards to increase the tension on the chain.
3. Tighten bolt [A] again.

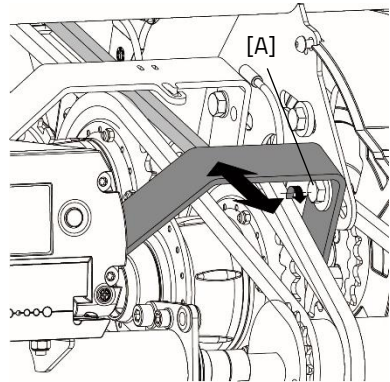

Adjusting the seat post

Over time, the seat post may develop some play which can be audible. To eliminate the play, the guide under the seat can be readjusted.

1. Loosen hex bolts [A and B] a few turns.
2. Press the plastic profile against the extrusion guide.
3. Tighten hex bolts [A and B] again.
4. Repeat these steps on the rear side of the guide attachment.

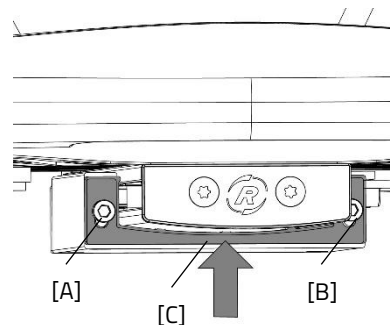

Disposal

If you want to dispose your tricycle, contact your dealer. You can also contact the local waste disposal company. They will dispose the tricycle according to the regulations of your town.

Recycling the Battery

If your battery is defective or if you are no longer using it, you must have it recycled. Please contact your dealer. They are responsible for complying with the recycling obligation. Ask them about the conditions or view the rules regarding recycling in your place of residence/country.

Handover/sale to a new owner

When you hand over your tricycle to a new owner it is important that you also hand over all necessary technical documentation and spare keys, so that the new owner can use the tricycle safely.

Do you use the Van Raam E-Bike App and have you linked your bike and battery to the app? Make sure you disconnect the bike and battery from the app when transferring/selling.

Guarantee

The guarantee is valid for all faults in the product, which are proven to be caused by material or manufacturing error.

We give a guarantee of five years on the frame and the front fork. For all accessories and other parts (except wear parts) we provide a two-year guarantee, as legally regulated. The guarantee only applies for normal use and maintenance of the tricycle, as described in this manual.

Beware!

The guarantee as well as the product liability in general expires if the instructions stated in this manual are not followed. This is also the case if unauthorized maintenance is carried out or if technical changes or additions are made with non-original Van Raam parts

without permission of Van Raam. The original CE certification will become nul-and-void if modifications are done by third parties. The absence of the certification can lead to problems in insuring your bike, and for any loss or incurred.

Frame number

The frame number is printed on the sticker. This sticker is located on the frame, see the image below.

Example sticker:



The decal is located on the back of the frame tube for both the Fun2Go 2 and the FunTrain 2:

On the back of the frame



On the back of the frame



Maintenance recommendation

A Van Raam bike often is subject to extensive use and must perform in all weather conditions. By correctly maintaining the bike, the lifecycle can be extended greatly. This maintenance can be done by a Van Raam dealer. In most cases, you can do the monthly and annual inspection yourself.

Maintenance Overview:

What	One-person bike	Multi-person bike	Duration	By whom?
1 st service moment	3 months/300 km	3 months/200 km	15 min	Dealer
2 nd Service moment	6 months/1.000 km	6 months/500 km	15-30 min	Dealer
3 rd Service moment	12 months/2.000 km	12 months/1.000 km	30-90 min	Dealer
Monthly inspection*	Every month	Every month	15 min	User
Annual inspection*	Every 12 months	Every 12 months	60 min	User

* This is advised to extend your bike's lifecycle. You can also have this done by your dealer.

Monthly inspection

15 minutes

Among them:

- Check and inflate the tyres
- Check the chain tension and grease if needed
- Tighten bolts/nuts where needed
- Check all lights
- Check the brakes
- Check all rotating parts and grease if needed
- Clean the bike

Annual inspection

60 minutes

Among them:

- Check and touch up the paintwork
- Check wheels for damage to rim, tire, spokes, hub and bearings
- Check spoke tension and wheel trueness
- Check the steering ball joints
- Check all lights
- Check the saddle clamp
- Check the placement of all electric components (E-Bikes only)

1st Service moment

15-30 minutes

Among them:

- Check tyres and inflate
- Check the spoke tension
- Check the chain tension and grease
- Tighten any bolts and nuts if needed
- Check all brake cables and brake callipers
- Check the gears
- Check and grease all rotating parts
- Check all lights
- Clean the bike

2nd Service moment

30-90 minutes

Among them: All points from service moment 1, and:

- Checking the pedals and bottom bracket
- Checking and lubricating the lock
- Disassembling, assembling, and greasing the steering stem
- Check the steering ball joints
- Run all tests in the dealer tool (E-Bike)

3rd Service moment

60-120 minutes

Among them: All points from service moment 1, 2, and:

- Inspection of the paintwork
- Inspection of the frame/front fork
- Inspection of the seat cushions
- Inspect the functioning and sound of the motor/gear hub
- check reflectors for any damage
- Check all electric components on their placement (E-Bike)
- Run all tests in the dealer tool (E-Bike)

Service plan

1st Service moment

- Yes/No
- Dealer:
- Mechanic:

Date:

Remarks:

.....

.....

.....

.....

2nd Service moment

- Yes/No
- Dealer:
- Mechanic:

Date:

Remarks:

.....

.....

.....

.....

3rd Service moment

- Yes/No
- Dealer:
- Mechanic:

Date:

Remarks:

.....

.....

.....

.....

Annual inspection

Date	Dealer	Mechanic	Remarks

Delivery and service form

Congratulations on your purchase of your Van Raam tricycle. This bike is produced with utmost care. To guarantee the quality as much as possible Van Raam produces the cycles according to the ISO 9001:2015 quality standards. Van Raam has been certified by DNV GL Business Assurance BV.

You will especially enjoy your Van Raam bike when the bike is adjusted to your specifications and when the instructions in the user manual are followed. Pay special attention on the service intervals who specified in the manual of the bike.

To claim warranty and service you should always fill out this form, at least at delivery and service. This signed form declares that the end user had an instruction on the operation of the tricycle, that the tricycle is adjusted to the specifications of the end user and that the user manual is received.

Fill out when the tricycle is delivered

Type Van Raam tricycle:	
Frame number:	
Key number:	
Delivered to:	
By dealer:	
Place:	
Date:	
Signature user bike:	Signature dealer:
When available, stamp dealer:	