

User manual



Husky



Mini



Midi



Maxi



Maxi Comfort



Viktoria



Viktor

Van Raam
Guldenweg 23
7051 HT Varsseveld, The Netherlands

☎ +31 (0)315 – 25 73 70

✉ info@vanraam.com

🌐 www.vanraam.com



Version 22.03

Table of contents

Manufacturer contact details.....	3
Conformity.....	3
Introduction.....	3
Delivery.....	4
Indication.....	4
Intended usage	4
Safety measures.....	5
Adjustment of the tricycle.....	7
Before the first use.....	10
Electro system Silent	16
Van Raam E-Bike App.....	24
Accessories.....	26
Technical specifications	32
Maintenance and adjustments to be done by owner	33
Repairs and maintenance to be done by dealer	34
Adjustments to be done by dealer	35
Disposal	36
Handover/sale to a new owner	36
Guarantee	37
Frame number.....	38
Maintenance recommendation	40
Service plan.....	42
Delivery and service form	47

Manufacturer contact details

Van Raam
Guldenweg 23
7051 HT Varsseveld, The Netherlands

 +31 (0)315 – 25 73 70

 info@vanraam.com

 www.vanraam.com

Conformity

Van Raam declares as manufacturer that the tricycles, as described in this manual, are produced in accordance with the Medical Devices Regulation (EU) 2017/745, risk category 1. All products have been produced in accordance with the 2006/42/EG guidelines. The signed declaration of conformity can be found on the Van Raam website.

Introduction

This user manual provides important and necessary information about the use of your tricycle. We ask you to read this manual thoroughly before using the tricycle. Always follow the instructions as provided in this user manual and keep the manual carefully. The most current version of the user manual can be found on the product page of the bicycle on the website www.vanraam.com.

All safety and user aspects have to be made clear to children and to people with limited powers of perception by a responsible and supervising person.



READ CAREFULLY

Delivery

Your delivery should include the following:

- Tricycle with packaging
- User manual(s)
- Possible Smart-battery including card with 5-digit code (depending on options)
- Possible chargers (depending on options)
- Spare keys

Check the delivery immediately after receiving it. In case of damage or incomplete delivery we ask you to contact your dealer immediately. Upon delivery you should fill out the form "Form service, maintenance, modifications an warranty claims" in the back of this manual.

Indication

Children or adults who cannot use tricycles or vehicles due to their handicap, are able to ride these tricycles. The tricycles can be used by children or adults with neuro-muscular disorders such as paralysis of the brain and muscular dystrophy. This also applies to people suffering from co-ordination problems, loss of balance and limited natural movements. If necessary, supervision may be desirable.

Intended usage

The tricycles are designed for normal use on level and solid ground. In general, tricycle caution should always be observed when using the tricycle. Moreover, the safety instructions as described in this manual should be explicitly followed. Local traffic laws and regulations should also be observed.

The tricycles is meant for one person. The driver should be independently mobile and may not have any serious visual or other impairments, which prevent responsible participation in traffic. The maximum user weight and luggage load (to be found in the chapter '**Technical Specifications**') may not be exceeded.

The manufacturer is not responsible for any damage or injury caused as a result of or during the course of any other type of use.

Safety measures

- Ensure the tricycle is in good condition each time before using it. Check before **each** ride that the brakes are in order. Check the lighting and make sure there is enough tyre pressure.
- Regularly check if the wheels, the handlebars and the saddle are properly fixed and also whether all screw joints are tight.
- Only use the tricycle on a **solid and level surface**.
- It is not recommended to cycle on a slope steeper than 10%, this carries an increased risk.
- It is advised to **drive slowly on slopes**, especially when riding backwards. When braking while riding backwards, it is advised to use a dosed braking force. When doing so, avoid the bike losing contact with the road.
- In the case you stand still on a slope or ramp, proceed to drive off slowly. While driving off you can lean forwards to prevent the front wheel being lifted.
- Avoid riding on steep slopes when your bike is fitted with one of the following accessories on the rear of the bike: Walking Holder bracket, wheelchair holder, child seats, or loaded baskets. In these cases the front wheel of your bike may lose contact with the road more easily.
- Make sure that wide trousers or loose hanging clothing don't get caught in the chain, spokes or pedals.
- Do not use a pressure washer or a steam cleaner for the cleaning of the tricycle.
- Block the tricycle to stop it from moving when you are getting on or off the tricycle. Do this by using the parking brake and holding the tricycle.
- Always lock the tricycle when leaving it unattended.
- Make sure that you do not reach a dangerous speed when driving downhill and entering tunnels. Brake in time and bike at a moderate speed.
- In case of pregnancy, extra care is required owing to a higher risk of injury.
- Do not leave the tricycle in direct sunlight: the temperature of some parts could exceed 41°C resulting in possible burns to the skin.
- If your tricycle is equipped with the Silent electric motor system, make sure that you get used to riding with the electric support engaged. Be careful when you

turn on the electric support system and make sure you don't get startled by unexpected behaviour because you turned on the electric support.

- Practice the reverse function! Please be careful not to switch on the reverse function of the electric motor inadvertently.



Extra attention is essential if a child is using the tricycle!

- **Never** leave a child alone with the tricycle without supervision!
- **Always** have the child wear a tricycle helmet! Make sure the helmet fits correctly!
- Have the child wear visible reflective clothing, so they are visible to other road users!
- Warn the child to ensure that no dangerous speed develops while driving downhill and entering tunnels. Brake on time.
- It is advisable to fit a flag onto the tricycle that is visible above the child.

Load

The maximum load should not be exceeded. See the information in the technical data table in the **'Technical Specifications'** section of the user manual. By permitted load we mean the total load, including the load on the luggage rack (or in the basket).

Make sure that the permitted load on the luggage rack and in the basket is not exceeded. (**maximum** 20 kg). People may not be transported on the luggage rack or in the basket!

Be aware that a basket full of luggage can influence the steering considerably. No luggage that limits the use of the tricycle can be transported on the handlebars.

Damaged or worn out parts

The replacement and repair of parts (frame, forks, light, brakes, drive mechanism and the handlebars) should **always** be performed by an authorised dealer. If not, the guarantee ceases to be valid and you will be personally responsible in the event of possible damage.



Specific safety parts should **always** be replaced by new parts!

Adjustment of the tricycle

Before using the tricycle, adjust it to the measurements of the cyclist. This is of great importance, especially the saddle and the handlebars.



If an optimal adjustment of the tricycle, as defined in the instructions, is not possible, you can contact your dealer for a fitting solution.

The brakes are correctly adjusted and should only be adjusted by the dealer during periodic maintenance.



Take care that fingers and limbs do not get trapped while adjusting the tricycle.

Saddle height (Husky, Mini, Midi, Maxi, Maxi Comfort, Victoria, Victor)

When the cyclist is sitting on the tricycle and can put a foot on the pedal in the lowest position, the saddle height is correct. Adjust the saddle height in such a way that the leg is stretched but relaxed in that position.

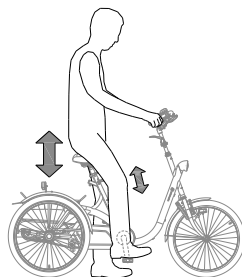

To adjust the saddle:

1. Slightly loosen the screw [A] using an Allen key.
2. Slide the saddle to the correct height.
3. Tighten the screw.

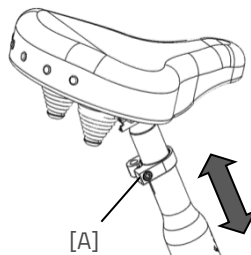

Do not pull out the saddle pin **further** than the marking. The tube will not go into the shank deep enough and will risk coming off. This can lead to serious injuries.



Handlebars height (Husky, Mini, Midi, Maxi, Maxi Comfort, Viktoria, Viktor)

The height of the handlebars affects the comfort of the ride. It determines the pressure on the hands and the position of the back. You decide the most comfortable position yourself with some practice.

To adjust the handlebars:

1. Slightly loosen the screw by using an Allen key.
2. Slide the handlebars to the correct height and tighten the screw very firmly again.

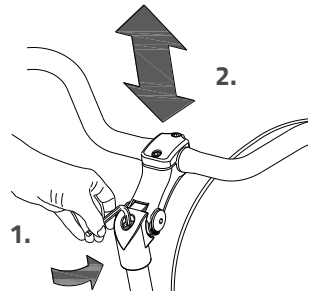

Do **not** pull out the handlebars **further** than the mark. Otherwise the tube will not be deep enough in the shaft and will risk coming off, which can lead to serious injuries.



Position handlebars (Midi, Maxi, Maxi Comfort, Viktoria, Viktor)

You can tilt the handlebars. This influences the distance from the handlebars to the upper body. Determine your own most comfortable position by using the tricycle.

To tilt the handlebars:

1. Slightly loosen the screws [A] with an Allen key.
2. Put the handlebars in the desired position and then tighten the screws considerably.
3. Slightly loosen screw [B] with an Allen key, put the handlebars in the correct (horizontal) position and then tighten the screw again.

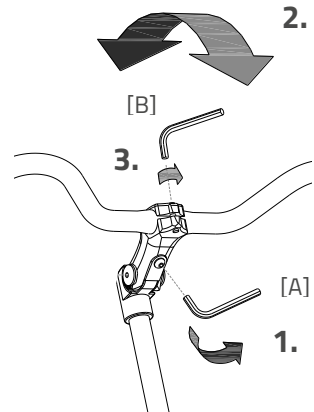

Before the first use

Parking brake

Always use the parking brake if you park the tricycle and leave it behind.

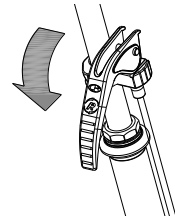

Block the tricycle with the hydro brake when passengers are getting on and off.

To operate the parking brake, squeeze the left brake [A] and secure the brake with the lever [B].

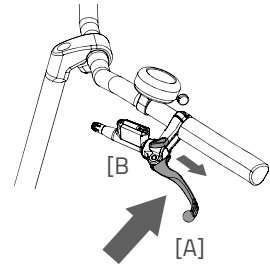

Always try to park the tricycle on a level surface. The tricycle may never be parked on a slope bigger than 6 degrees.

Lighting

Normally, the lighting on your bike can be operated manually and set to different modes. However, if your bike is equipped with the Silent Elektro system, your lighting will automatically turn off when the electric system is activated. The controls of both the manually operated and centrally operated lighting is explained below.



The Husky has no lighting. We recommend using the tricycle only in daylight.

Manually operated headlight

(Mini, Midi, Maxi, Maxi Comfort)

The headlight has a button with three different modes: ON – ON [50%] – OFF

Adjust the angle of the headlight to its correct position, when the centre of the light beam is about 10 metres in front of the bicycle.

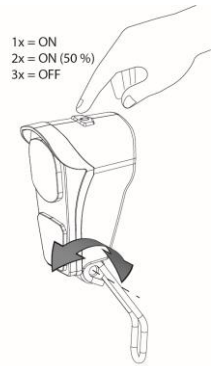

The headlight is powered by batteries. When the batteries are nearly empty, the LED light in the button of the headlight will turn red. Follow the steps to change the batteries of the headlight.

1. Open the headlight by pushing down the tab on the housing and simultaneously pulling the front of the light outward like shown.
2. Change the two alkaline batteries (2x AA).
3. Put the light back together by first pushing the top of the light back into the housing and then pushing the bottom of the light back over the tab of the housing.

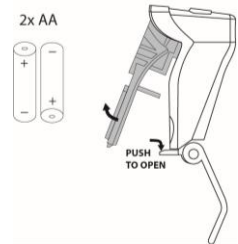

You can only operate the light while your bike is standing still to avoid dangerous situations and to avoid the chance of entrapment.

Manually operated rear light

(Mini, Midi, Maxi, Maxi Comfort)

The rear light has three options which you can choose by pressing the button repeatedly: **On-Auto-Off.**

The setting is as follows:

Press 1x: light is on

Press 2x: lighting is automatic

Press 3x: light is off

With the "On" or "Off" mode, the rear light can be manually switched on and off.

With the "Automatic" mode the rear light automatically turns on and off with the help of light and movement sensors. When the tricycle stands still for a while, the light will automatically turn off.

The rear light works on batteries. When the batteries are almost empty, a red LED light on the top starts flashing. To replace the batteries, follow the next steps.

1. Dismantle the cover of the holder by pressing in the lip at the bottom of the light.

2. Replace the alkaline batteries (1,5 V - 1500 mA) and assemble the cover.



*Batteries cause environmental pollution.
Follow the local regulations during disposal.*

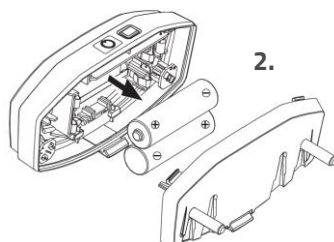
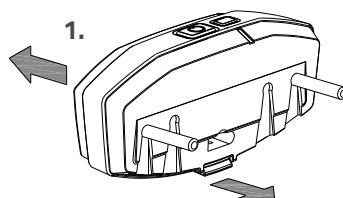
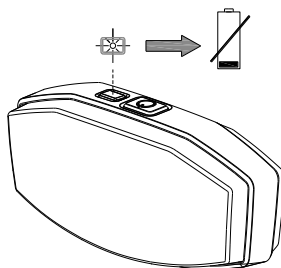
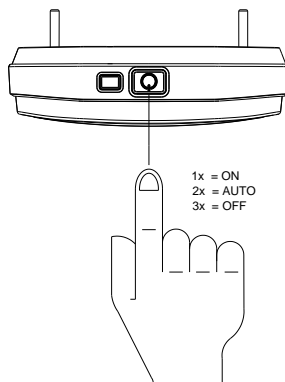

Centrally Operated Lighting

The bike has been equipped with centrally operated lighting, with the lighting being connected to the electric system. The lighting will turn on automatically when the electric system is activated.

Adjust the angle of the headlight, so that the centre of the light beam is aimed about ten metres in front of the bike.

You can manually turn the lighting on and off by briefly pushing the on/off button on the display. When the electric system is turned off, the lighting will turn off automatically.

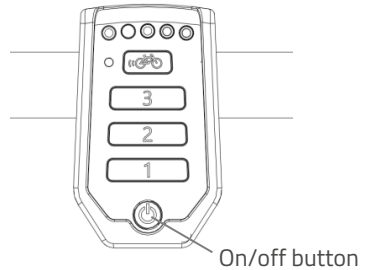
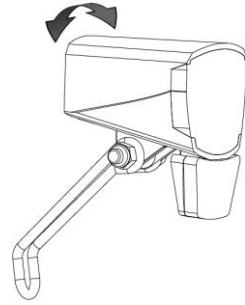

Make sure there is always a battery on the bike when you are cycling after dark!

Once the battery is nearly empty, the motor will no longer provide pedal support power assistance while cycling. The lighting will still be powered by leftover power.



The USB port in the headlight has no function.

Gears

The tricycle has no gears or eight gears. The gear is operated by turning the grip.

Do not use the pedals when turning the grip.

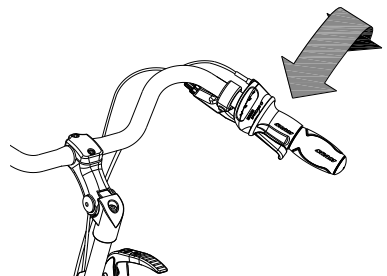

Check before every ride:

- The brakes (including the parking brakes)
- The tyre pressure (recommended: 3 bar)
- The lights
- That all parts are fitted properly
- That the battery is adequately charged (depends on options)

Contact your dealer and stop using your tricycle as soon as you observe irregularities during the check!

As with all mechanical parts, the tricycle is subject to wear tear and high loading. If a component fails, it can lead to very dangerous situations. This can lead to damage or injuries to the user of the tricycle. Any form of cracks, scratching or change in colour in heavily loaded parts or a component indicates that the component must be replaced.

Points of interest during cycling

After you have adjusted the tricycle to the measurements of the cyclist, you can start using the bike.



The tricycle gives a very different ride experience than a bicycle!

Practice, in particular, with bends and braking, because a tricycle can react contrary to what you would expect. It may happen that the back wheel comes off the ground on the inside when going round a bend. To avoid this the rider leans towards the inside of the bend with his body.

One of the brake levers (usually the right) operates the brake on the front wheel. This deserves special caution, as a forceful braking could block the front wheel, which could result in a fall. The driver should be familiar with controlled braking of the front wheel!



If there is an electric motor on a bike: you must train with the acceleration function and reverse functions. Be careful that the acceleration mode or reverse mode are not unintentionally started while using the bike. For example, at traffic lights the reverse function can accidentally be activated and the tricycle reverses.



High speeds in the bends, driving on rough ground, and sharp bends can lead to the tricycle **falling over!**



Extra attention is essential if a child is using the tricycle or a person with limited powers of perception is using the tricycle!

Before a child or an adult with limited powers of perception rides the tricycle independently for the first time, they should practice first under your supervision (or under the supervision of others).

Pay special attention to bends, because this can be a great source of danger. Also explain that the widest part of the tricycle is situated behind the driver. Let them practice passing several obstacles, to get a feel of the width of the tricycle!

Children or adults with limited powers of perception should **always** be made aware of the possible dangers of using a tricycle.

Important safety points for the cyclist

- Be very careful during the first ride.
- When riding the tricycle hold both hands firmly on the handlebars and feet on the pedals.
- Test the riding style of the tricycle on rough ground at moderate speed. This way the cyclist learns how to react to unexpected movements of the tricycle and the handlebars during use.
- Explore how the tilting movements of the tricycle react to body posture. Tilt to the inside of the bend.
- Small obstacles should be cycled over with appropriate speed.
- Obstacles higher than five centimetre should be avoided.
- Ensure that no dangerous speed develops while driving downhill and entering tunnels. Brake on time.

Electro system Silent

The Silent Electric motor system is a special developed support system by Van Raam for the rehabilitation market. The system is characterized by:

1. A simplicity of operation
2. Individually adjustable support for cycling
3. Modern and efficient electronics
4. The powerful electric motors
5. High quality and safe batteries
6. Highly reliable system

The Silent system comes standard with a basic support mode individually programmed for your bike. In most cases, it gives precise and smooth cycling characteristics with a good compromise between support and radius of action.

In special cases, an individually tailor-made cycling program is necessary. You can obtain information from the dealer about the possibilities of a customised cycling program.

Functions:

The electric system has the following functions:

- Pedal support while cycling
- Start support
- Backwards pedalling with support
- Intergrated lighting control

1. On/off button

Using the on/off button, the electrical system can be switched on or off.

- Switching on: Push the button briefly.
- Switching off: Push the button for two seconds.

After the system is turned on, the electric motor is active in level 1.

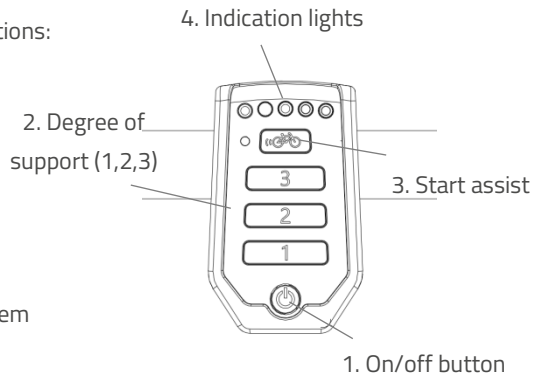



When the system is not used, it will automatically turn off after a certain time.



Always turn off the electric system before getting on and off the bike, and when you are walking while holding the bike.

2. Degree of support 1, 2 and 3

The desired support can be set by using one of the support levels 1, 2 or 3.

1. Light support, maximum range.
2. Average support, average range.
3. Maximum support, low range.

You can change the level while cycling.



The behaviour of the battery depends on a lot of different factors and is strongly influenced by: capacity and voltage of the battery, degree of support that is used, temperature, wind speed, tyre pressure, cycling speed, weight of the user and the luggage, use of gearing etcetera.

3. Start assist

The Silent electric motor has a start support. This allows the driver to pull-away without pedalling up to a speed of 6 km/h over 6 seconds. To accelerate, press the start assist button and keep it pressed down. The function will only activate again, when the support button has been pressed down again. If you peddle normally, the function works for up to 6 seconds, each time the button is pressed, up to maximum speed of the bicycle (20-25 km/h).

The start assist is used for:

- Extra support when starting.
- Extra support for cycling uphill.



When cycling a steep climb, you can use support in level 3 and push the start assist repeatedly for 6 seconds to achieve maximum support.

4. Indication lights

The level of charge in the battery is given by five LED lights: four of these are green, the one on the left can show either green or red, if charge is low.



The battery is fully charged. When in use, the number of green LED lights on the battery will decrease.



The battery is 50% charged when two green LED lights are on.



The battery is almost empty if only the last red LED light is on. The battery needs to be recharged or replaced by a (new) fully charged battery.



When the last red LED light flashes, the battery is empty and the motor will no longer support while cycling. The integrated lighting continues to work.

The battery is equipped with a button and indicator that makes it possible to check the charge by briefly pressing the button [A]. The status of the battery is shown with five green indicator LEDs, of which the left most one can blink. That means the battery is nearly empty. During charging, the battery displays the progress of the charging.

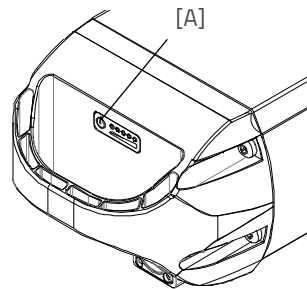

Reverse mode

The reverse mode is activated by pedalling backwards from a standing position. Within a few seconds the motor is activated and the tricycle cycles at a speed of about 2 km/h backwards (when you start to pedal backwards).



Do not be startled by an unexpected reaction from the electrical system. If you e.g. wait for the traffic light and you play with the pedals by moving them backwards the reverse mode is activated and the tricycle cycles backwards.

Centrally Operated Lighting

The bike is equipped with centrally operated lighting, with the lighting automatically turning on when the electric system is activated. Further instructions can be found in the chapter 'Before the first use'.

Other functions

The smart display has an automatic dimming function. With an inbuilt light sensor the lights of the display will automatically creating less distraction for the cyclist in darker or more shadowy conditions.

Charging the Battery

For the best performance and to prolong the life of the battery, we recommend that you charge the battery at home at room temperature.



Only use the charger if the temperature of the environment is between 0 and 35 degrees centigrade.

To charge the battery:

1. Unlock the battery by turning the key a quarter.
2. Push down and hold the lock. Then pull the battery out of the holder with your other hand.
3. Take the battery pack inside. **First** plug the charger into the socket. The green LED will light up. The charger is now on standby.
4. **Then** insert the charging connector of the charger into the charging point of the battery. The red LED will light up. The charger is now charging.



Please note! If the battery is not connected properly, the green LED will light up (standby mode). If the connection is poor, unplug the plug from the socket and clean the charger's connector with a dry cloth.

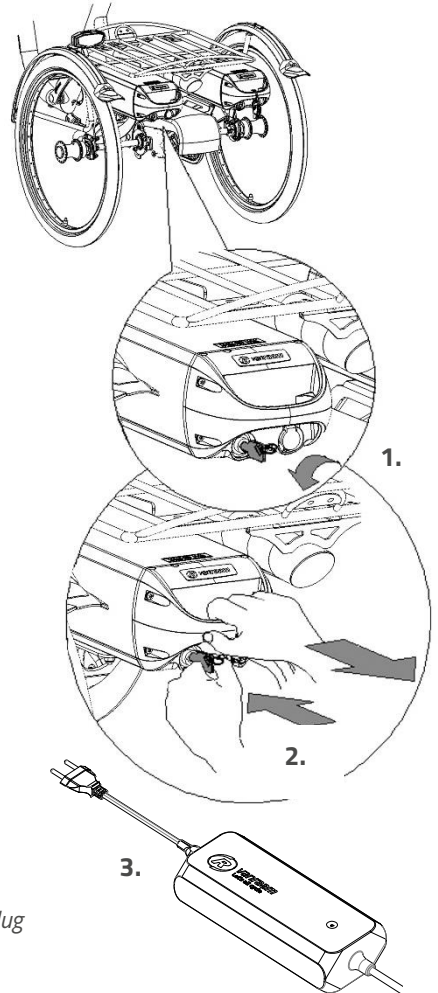

5. The charging time depends on the level of the battery. The charging time is approximately 2 hours with a 11,4 Ah/36 V battery and approximately 4.5 hours with a 24,8 Ah/36 V battery.
6. Once the battery is fully charged, the green LED will be solid. Now **first** remove the charging connector of the charger from the connector of the battery.
7. **Then** unplug the charger from the socket.
8. Put the battery back in the holder of the cycle and close the lock.

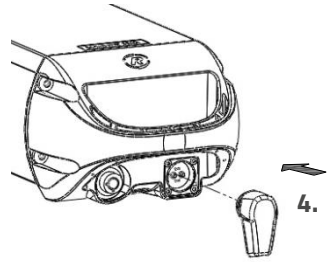

If necessary, the battery can also be charged directly on the cycle.

Charger:

LED indication	Status
Green	Standby / battery full
Red	Charging
Red, blinking	Safety: Polarity inversion; Short; Over temperature; Over power; Over voltage



It is better for the battery if it is charged regularly, rather than wait until it is completely drained. Never leave the bike with a drained battery!



Ensure that the battery is always pushed straight into the holder.

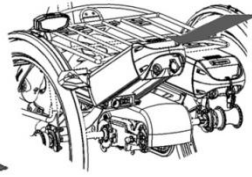
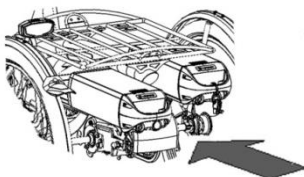

Backup battery (optional)

The bike can be supplied with a second battery. When the first connected battery is empty, switch over to the second battery.

One of the battery holders is connected to the system, you can recognize this one because of the cables.

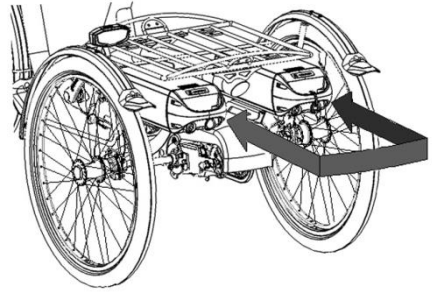

Switchable battery pack (optional)

The bicycle may be fitted with a switchable battery pack. Once the connected battery is empty, you can swap the battery using a switch. This switch is located either under the seat, below the luggage rack or below one of the two batteries. Both batteries are connected to the system. If desired, you can leave the second battery to charge when you are using the other.

Battery Deep Sleep Mode

When the battery is nearly empty and has not been used for a week, the battery will enter deep sleep mode. In this mode the battery uses as little power as possible, to increase the lifespan of the battery.

When the battery is in deep sleep mode, it cannot be used. By pressing the button on the battery, the battery will be woken up from deep sleep mode, and it can be used again. It is recommended to first charge the battery before using it in that scenario.

Charging and maintenance tips for the battery

- Never leave the bike with an empty battery! We advise you charge the battery as soon as possible before it's totally empty.
- The best storage-charge of the battery is when three to five LED lights are lit.
- Check the battery every month in the winter. If fewer than three LED lights burn, recharge the battery.
- Preferably store and use the battery in environments of 5 to 20 °C. Avoid higher or lower temperatures.
- Do not charge the battery in sunlight and make sure that the battery is not charged at a temperature of less than 5 °C.

- Only use the charger indoors and in non-humid environments, the charger may *not* get wet.
- Only use the Van Raam supplied battery.
- Only charge the battery with the supplied charger!
- The battery housing and charger housing may never be opened! When there is a problem, contact your dealer.
- The Van Raam battery may not be revised due to serious safety risks and the incorrect functioning of the electric system as a whole.
- Don't drop the battery, this can cause external and internal damage.
- If your bicycle has a fault, the battery should be disconnected from the bicycle.



Keep in mind that your bike provides less support when it's cold (0°C and less) and the battery will discharge faster. Charging also takes more time at lower temperatures.



Every battery discharges automatically over time. This process is called self-discharge. A battery that is empty and not charged, will self-discharge and will be deep discharged. The battery can be permanently damaged during this process. In case of deep discharge, the warranty will be void.



Please note that any battery will wear over time. The wearing process of the battery is inevitable and depends on several factors, such as usage, number of charge cycles and the ambient temperature. Even if the battery is not used, its capacity will decrease. A worn battery can still be used, but please bear in mind that its charge level may decrease.

Possible malfunctions

- The system does not turn on:
 1. Make sure that the battery is properly attached.
 2. Check the status of the battery. If it is empty, recharge the battery.
 3. If the above action does not help, contact your dealer.
- If the battery indicator LED lights on the display are flashing: The motor may be overheated by continuous high load. For protection, the system will reduce the support.
 1. The system is in temperature-protection. You can continue cycling with reduced support.
 2. After cooling down, the normal support and indication will restore automatically.

- If the support LED lights on the display are flashing: This indicates motor failure. You will need to contact your dealer.
- If a red LED light on the charger starts flashing, remove the plug from the mains outlet and do not longer use the charger. In this case, contact your dealer.

Charger Safety Measures

- Only charge Van Raam Li-Ion batteries with the included charger. Only connect the charger to a suitable power point (220-240 Volt AC 50-60 Hz). If the charger is not being used, unplug it from the socket and take the plug out of the battery.
- The charger may only be used by people who have read the information in this user manual and are familiar with the proper use of the charger. Keep the charger out of reach of children; do not let them play with it.
- The charger has been designed for use in a dust-free, dry, and ventilated environment. Do not expose the charger to water, heat sources, and direct sunlight. Keep the charger clean and dry.
- Do not charge batteries that feel hot to the touch. The battery may not be hotter than room temperature for charging. Stop charging if the battery becomes abnormally hot (>40°C).

Please note! The charger may become hot during charging > 50 °C. First carefully feel if it is safe to touch the charger. This temperature can cause sensitivity or startle if it comes into contact with the skin.

- Do not use the charger if it is visibly damaged or modified. Do not repair the charger! Please contact Van Raam. Never open the charger yourself!
- While charging, please monitor the charger and the battery. Once the battery is full, remove the plug from the socket and the plug out of the battery.

Van Raam E-Bike App

The Van Raam bicycle app is a free smartphone app that you can use while cycling on your electric Van Raam bicycle.

What can you do with the Van Raam E-Bike App for your Smart E-Bike?

- Can be used as a luxury bicycle computer.
- View battery data.
- Receive battery advice.
- Change bike settings.
- Send SOS message with GPS location to a number of your choice.
- View cycled routes.
- View information about the bike.
- Location/Find my bike.
- Receive push notifications.

With the Van Raam App, a connection can be made with the smart display via Bluetooth connection. As soon as the smart display is ready to connect to the smartphone, the on/off button will briefly turn blue.

This app can be used as a luxury bicycle computer for Van Raam bicycles with pedal assistance and also contains many other extra functionalities. The dashboard on the app shows the current speed, total distance, trip meter, battery capacity and power consumption during the bike ride. For more cycling data, there is a details screen including average speed, maximum speed, total distance, power, battery voltage, pedalling power and pedalling frequency.

The Van Raam E-Bike App can be downloaded free of charge from the Google Play Store or Apple App Store.

For more information about the Van Raam App, you can visit the Van Raam website: www.vanraam.com.





From the 15th of July, 2020, all electric Van Raam bicycles will be delivered as Smart E-Bikes. You can recognize this by the large sticker with a yellow border on the battery. If you have a Smart E-Bike and you download the updated app, there are even more options. A Smart E-Bike collects technical data, such as battery voltages and electricity usage. This allows notifications to be sent if, for example, the battery power is getting low.

In addition, the Smart E-Bike also collects location data from the battery if you give permission for this as a user. Van Raam never collects personal data such as the GPS location without your permission. More information about the data that is collected can be found in the Privacy and Cookie statement on the Van Raam website.

Accessories

Depending on your order, you can use the accessories as described below. Extra accessories are available at your dealer.

Push bar (Husky, Mini, Midi)

To fit the push bar:

1. Loosen the screw by using an Allen key.
2. Slide the push bar in the tube up to the stop. Then tighten the screw again very firmly by using the Allen key.

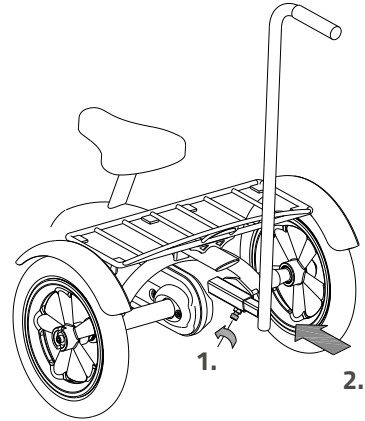

Crank shortener

The crank shortener is fitted to the crank, as illustrated. The pedal can then be fitted into the crank shortener at two positions.

With the screw [A] the crank shortener should be aligned with the crank.

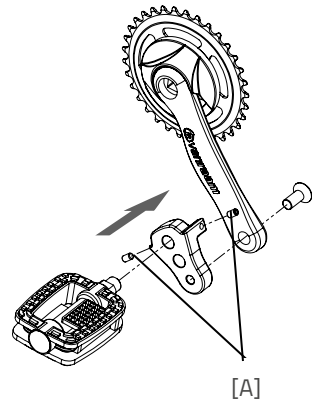

Eccentric crank

The tricycle can be fitted with an eccentric crank on the left and/or right side. The illustration may differ from your crank, because it is custom made.

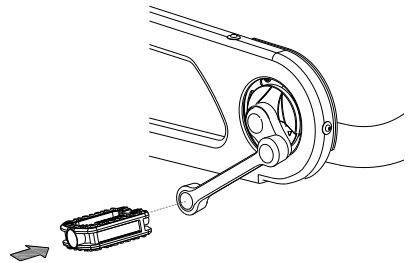

Foot support

When using the foot support you can fix your foot by sliding the two straps [A] in the quick releases [B].

The quick release can be unlocked by pulling the lip to the rear. Now the strap can be pulled out.

You can cut the straps to size. The strap should retain a length of at least five centimetre.

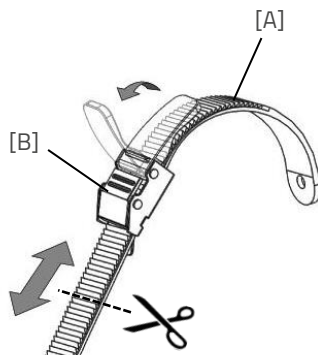

The position of the foot support on the pedal is adjustable in length. This allows you to pedal with the ball of your foot for better thrust.

1. Slightly loosen the four nuts with a socket wrench.
2. Slide the plate included the foot support forwards or backwards into the desired position. Then tighten the nuts again.

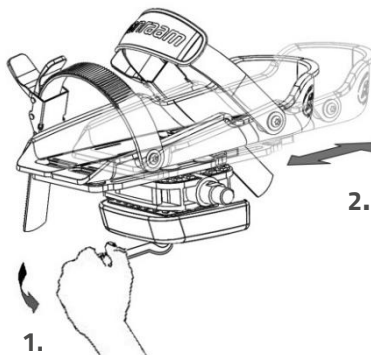

The foot support is also adjustable in width. Only the outer half of the foot support can be extended.

1. Slightly loosen the two screws with an Allen key.
2. Slide the adjustable half of the foot support to the desired position. Then tighten the screws again.

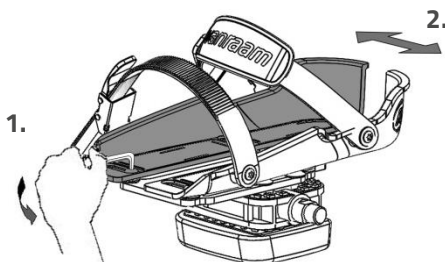
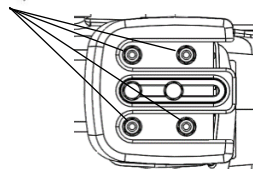

With the axel pedal extender the foot support can be extend further.



The small foot support (Fix20) is suitable for shoe sizes 22 up to size 36. The width of the range of this foot support is min. 6,5 cm to max. 9 cm. The large foot support (Fix25) is suitable from shoe size 37 up to size 48. The width of the range of this foot support is min. 8,5 cm to max. 13 cm.

The foot support returns to its neutral position when it is not used. The neutral position can be altered by shifting the balancing block.

1. Slightly loosen the two screws with a socket wrench.
2. Slide the balancing block to the desired position. Then tighten the screws again.

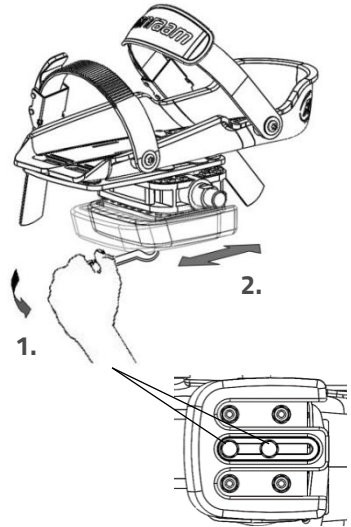

Lower Leg Fixation

With the optional lower leg fixation, you can secure your lower leg. In order to set up the lower leg fixation:

1. Loosen the bolt [A] several turns using a nut spanner. Adjust the height of the lower leg fixation to the lower leg of the rider. Now tighten the bolt again.
2. Loosen the two nuts [B] several turns. The angle of the leg cup can now be adjusted. Rotate the leg cup in the correct position and retighten the nuts.
3. Use the Velcro to secure the lower leg.

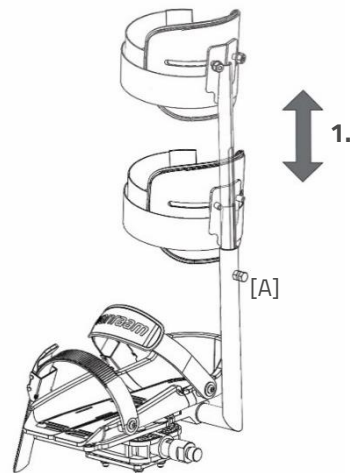
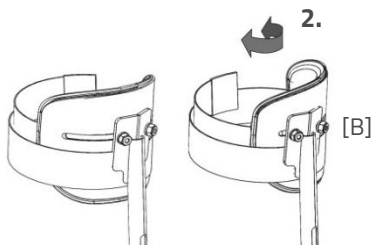

Dividable frame

The tricycle can be divided into two parts. To divide the frame:

1. Use the parking brake.
2. Remove the grip from the handlebars. Push the pellets of the small spring [A] so that the grip can be removed from the handlebars.
3. (Electrical only) Disconnect the Velcro band so that you can reach the connectors.
4. (Electrical only) Disconnect the connectors. Pull the black connectors straight apart. Disassemble the metal connector.
5. Loosen the knob.
6. Remove the front part out of the coupling.

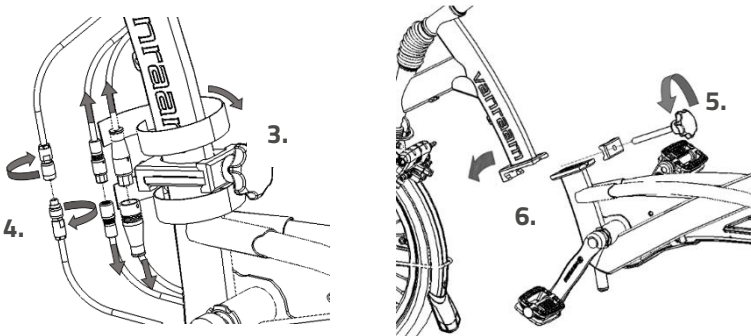
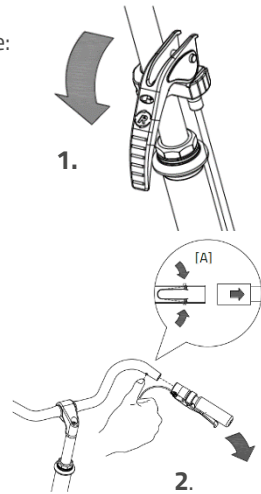

To assemble the tricycle again, follow these steps in reverse order. When connecting the cables, make sure that the arrows or cams are directly opposite to each other.

Walking-stick holder

You can take two walking-sticks with you in the stick holder. Place the walking-stick in the holder at the bottom side [A] and then secure the stick in the fastening device [B] at the top side. Always fasten the walking-stick(s) with the Velcro band.

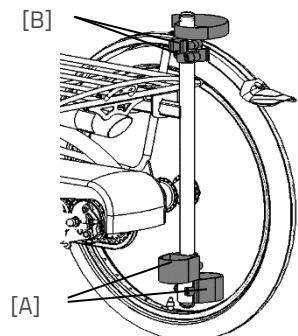

Back support

Fit the back support under the saddle with the hexagon socket [A].

First adjust the right depth, by loosening four nuts [B], putting the back support in the right position and then tighten the nuts again.

Then adjust the right height by loosening the two nuts [C], sliding the support in the correct position and then tighten the nuts again.

The back support can be fitted with a belt [D]. Use the fastening device to open and close the belt.

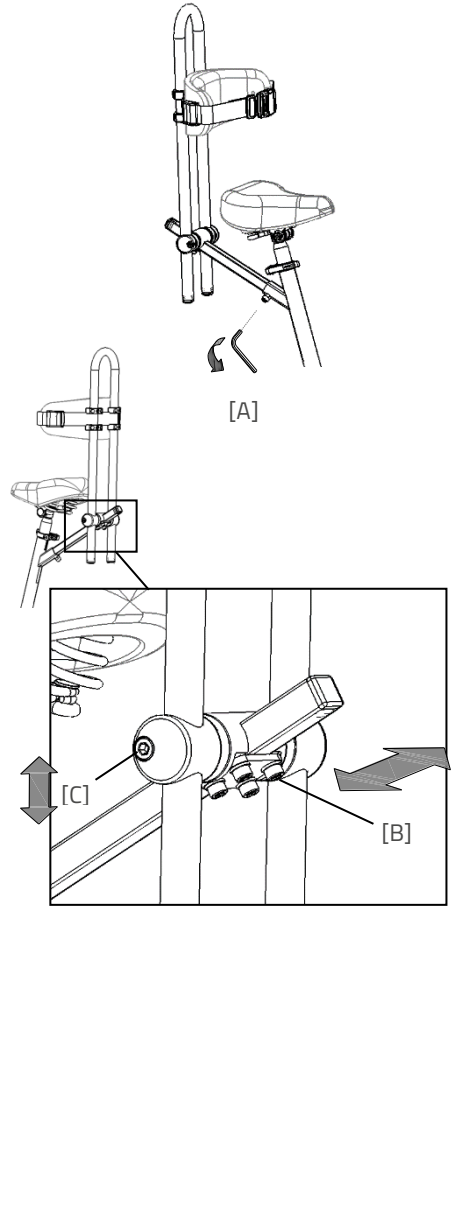

Flashing light system

To use the flashing lights press the switch [A] to the left or right.

To turn off the indicators, move the switch to the centre position.

The lights work on a battery. To replace the batteries, turn the screw on the cap and take the orange cap [B] away. Then remove the PCB [C] from the holder. You can now replace the battery [D].

This is a 3-volt lithium battery, CR123A.



Batteries cause environmental pollution. Follow the local regulations during disposal.

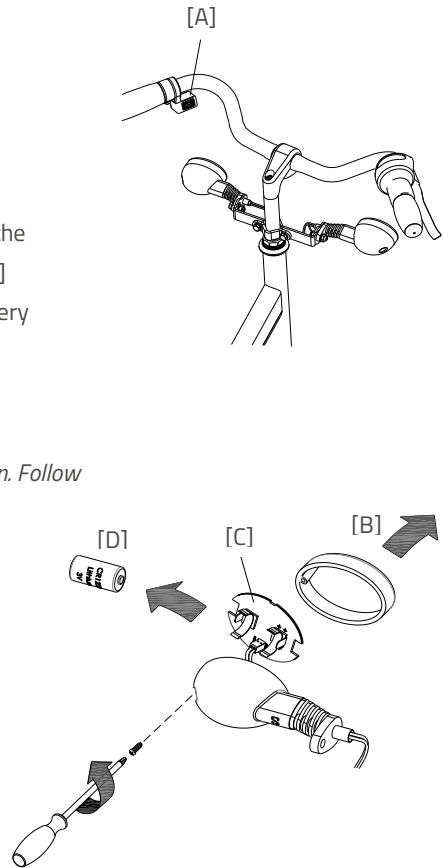

Technical specifications

	Husky2	Mini3	Midi2	Maxi2	Maxi Comfort
Length of inner leg (cm)	35-47	47-59	66-80	80-95	67-82, 76-91 ¹ , 85-100
Frame height (cm)	23	30	41	53	42, 51 ¹ , 60
Length (cm)	98	136	168	180	194
Width (cm)	59	60	75	75	75
Height (cm)	68	88	108	124	118
Weight (kg)	appr. 11	appr.. 21	appr. 27	appr. 29	appr. 32
Boarding height(cm)	12	20	25	28	23
Front wheel	12.5"	16"	20"	22"	24"
Back wheel	12.5"	16"	22"	24"	24"
Max. load luggage rack/ basket (kg)	20	20	20	20	20
Max. weight user (kg)	65	65	90	120	120
Brakes, front	V brake	V brake	V brake	V brake	V brake
Brakes, back	Non or V brake	V brake or Back pedal brake	V brake or Back pedal brake	V brake or Back pedal brake	V brake or Back pedal brake

	Viktoria	Viktor
Length of inner leg (cm)	63-80	75-93
Frame height (cm)	41	50
Length (cm)	155	173
Width (cm)	80	89
Height (cm)	-	-
Weight (kg)	18	16
Boarding height(cm)	18"	20"
Front wheel	24"	26"
Back wheel	ca. 30 (bare)	ca. 30 (bare)
Max. load luggage rack/ basket (kg)	-	-
Max. weight user (kg)	125 ²	125 ²
Brakes, front	V brake	V brake
Brakes, back	V brake or Back pedal brake	V brake or Back pedal brake

¹ Standard, ² Maximum user weight including luggage

Maintenance and adjustments to be done by owner

Below you can find the instructions for maintenance and adjustments that you can do yourself on a regular basis, which will keep your tricycle in top condition.

Cleaning

The frame of the tricycle can be cleaned with a damp cloth. For areas that are dirtier you can use a mild detergent. The wheels can be cleaned with a moist brush with plastic hairs (not a wire brush!). The saddle, the grips and the backrest can be cleaned with mild soap and water.



Do not use a pressure washer or a steam cleaner!

The right lubricant

The chain should be cleaned and maintained at regular intervals (every three months approximately). Only use special chain grease or Teflon spray. This is the only way to make sure that the chain will run smoothly, will stay water resistant and will not rust.

1. Wipe the chain with a cloth.
2. Treat it with grease or spray.
3. Remove any excess lubricant with a rag.

Other parts should **not** be treated with a lubricant.

Inspection of the tricycle

It is recommended that the tricycle has a yearly inspection carried out by the dealer to claim warranty. Please use the form "Form service, maintenance, modifications and warranty claims" in the back of this manual. After 200 kilometres or after a period of two months the tricycle should be inspected.

In the event of technical trouble or faults, the tricycle should be taken to the dealer for repairs **immediately**.

The replacing of safety-related components (especially frame, brakes, lighting, handlebars, front fork and actuation) should be performed by the dealer.

If you still decide you want to replace components yourself, you are responsible for damage or harm due to incorrectly fitted components. Only use **original** Van Raam spare parts, which you can buy at you dealer. If requested the dealer will make the necessary information on repair and maintenance available.

Repairs and maintenance to be done by dealer

Check the brakes, the rims, lighting, the chain tension and the spokes. Also check the tyre tread depth. This should be at least one millimetre. Worn out tyres or possible faulty parts should be replaced. Also check the parking brake. With the parking brake pulled up, the tricycle should not ride away with the cyclist.

Checking the rim

Due to the combined action of the brake and the rims, not only the brake lining but also the condition of the rim is important. For this reason the rim should be checked at regular intervals, for example when you inflate the tyres. The presence of fine cracks in the spoke punches or deformation of the rim when there is higher air pressure, indicate more serious wear and tear. In that case the rim should be replaced, because it can lead to loss of brake function or even a crack in the rim, which can lead to all kinds of dangerous consequences.

Repairs, maintenance and modifications should only be performed with original Van Raam parts.

Adjustments to be done by dealer

The correct tension of the chain

The chain should not be too tight. It should hang loose. Without effort you should be able to move the chain up and down, half a centimetre approximately.

Adjusting chain tension (Husky, Mini, Midi, Maxi, Maxi Comfort)

To keep the chain tension correct, a special tensioning wheel is fitted on to the tricycle, as an integrated chain tensioner.

1. Slightly loosen the screw. Hold the nut at the back tight with a socket wrench to stop the screw from slipping.
2. Shift the tensioning wheel in such a way that the chain hangs loose, as described above.
3. Tighten the screw again.

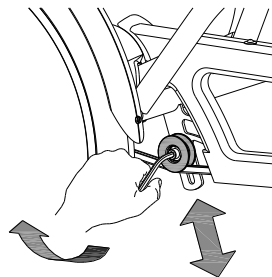

Adjusting chain tension (Viktoria, Viktor)

To keep the chain tension correct, the back wheel axle is adjusted. Follow the instructions below:

1. Slightly loosen the nuts of the back wheel axle, so that the back wheel can move backwards and forwards.
2. Slide the back wheel backwards, so that the chain is hanging loose, as described earlier. Also slide the bracket [A].
3. At the same time make sure that the wheel is straight and positioned in the centre of the frame, as illustrated. Not to the left or to the right.
4. Slightly tighten the nuts.

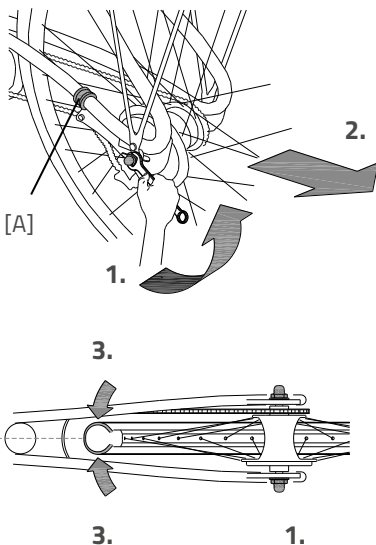

5. Check whether the chain tension is correct and whether the wheel is straight and in the centre of the frame.
6. Tighten the nuts again.

Disposal

If you want to dispose your tricycle, contact your dealer. You can also contact the local waste disposal company. They will dispose the tricycle according to the regulations of your town.

Recycling the Battery

If your battery is defective or if you are no longer using it, you must have it recycled. Please contact your dealer. They are responsible for complying with the recycling obligation. Ask them about the conditions or view the rules regarding recycling in your place of residence/country.

Handover/sale to a new owner

When you hand over your tricycle to a new owner it is important that you also hand over all necessary technical documentation and spare keys, so that the new owner can use the tricycle safely.

Guarantee

The guarantee is valid for all faults in the product, which are proven to be caused by material or manufacturing error.

We give a guarantee of five years on the frame and the front fork. For all accessories and other parts (except wear parts) we provide a two year guarantee, as legally regulated. The guarantee only applies for normal use and maintenance of the tricycle, as described in this manual.

Beware!

The guarantee as well as the product liability in general expires if the instructions stated in this manual are not followed. This is also the case if unauthorized maintenance is carried out or if technical changes or additions are made with non-original Van Raam parts without permission of Van Raam. The original CE certification will become nul-and-void if modifications are done by third parties. The absence of the certification can lead to problems in insuring your bike, and for any loss or incurred.

Frame number

The frame number is printed on the sticker. This sticker is located on the frame, see the images below. At the Viktoria and Viktor the frame number is stamped in the frame, see the images below for the positions.

Example sticker:



Position sticker Husky, Mini, Midi, Maxi and Maxi Comfort:

Husky



On the frametube

Mini



On the back of the saddle

Midi



On the back of the saddle

Maxi



On the back of the saddle

Maxi Comfort



On the back of the saddle

Positions of frame number, stamped in a plate on the frame (Viktoria and Viktor):

Viktoria



In a plate in front of
the hinge plate

Viktor



In a plate in front
of the hinge

Maintenance recommendation

A Van Raam bike often is subject to extensive use and must perform in all weather conditions. By correctly maintaining the bike, the lifecycle can be extended greatly. This maintenance can be done by a Van Raam dealer. In most cases, you can do the monthly and annual inspection yourself.

Maintenance Overview:

What	One-person bike	Multi-person bike	Duration	By whom?
1 st service moment	3 months/300 km	3 months/200 km	15 min	Dealer
2 nd Service moment	6 months/1.000 km	6 months/500 km	15-30 min	Dealer
3 rd Service moment	12 months/2.000 km	12 months/1.000 km	30-90 min	Dealer
Monthly inspection*	Every month	Every month	15 min	User
Annual inspection*	Every 12 months	Every 12 months	60 min	User

* This is advised to extend your bike's lifecycle. You can also have this done by your dealer.

Monthly inspection	Annual inspection
15 minutes Among them: <ul style="list-style-type: none">• Check and inflate the tyres• Check the chain tension and grease if needed• Tighten bolts/nuts where needed• Check all lights• Check the brakes• Check all rotating parts and grease if needed• Clean the bike	60 minutes Among them: <ul style="list-style-type: none">• Check and touch up the paintwork• Check the wheels for any buckling• Check the spoke tension• Check the steering ball joints• Check all lights• Check the saddle clamp• Check the placement of all electric components (E-Bikes only)

1st Service moment

15-30 minutes

Among them:

- Check tyres and inflate
- Check the spoke tension
- Check the chain tension and grease
- Tighten any bolts and nuts if needed
- Check all brake cables and brake calipers
- Check the gears
- Check and grease all rotating parts
- Check all lights
- Clean the bike

2nd Service moment

30-90 minutes

Among them: All points from service moment 1, and:

- Inspection of the pedals and bottom bracket
- Grease and tighten the lock
- Grease and tighten the steering stem
- Check the steering ball joints
- Run all tests in the dealer tool (E-Bike)

3rd Service moment

60-120 minutes

Among them: All points from service moment 1, 2, and:

- Inspection of the paintwork
- Inspection of the frame/front fork
- Inspection of the seat cushions
- Inspect the functioning and sound of the motor/gear hub
- check reflectors for any damage
- Check all electric components on their placement (E-Bike)
- Run all tests in the dealer tool (E-Bike)

Service plan

1st Service moment

- Yes/No
- Dealer:
- Mechanic:

Date:

Remarks:

.....

.....

.....

.....

2nd Service moment

- Yes/No
- Dealer:
- Mechanic:

Date:

Remarks:

.....

.....

.....

.....

3rd Service moment

- Yes/No
- Dealer:
- Mechanic:

Date:

Remarks:

.....

.....

.....

.....

Annual inspection

Date	Dealer	Mechanic	Remarks

Extra Maintenance and Check-ups you can do yourself:

Do you want ore tips and tricks on how to keep your bike in perfect condition? Check out the article: ['10 tips for the maintenance of a \(special needs\) bike'](#) on our website. In this article you can find tips about cleaning the bike, the seat padding, or for example how to maintain the battery of your E-Bike.



Delivery and service form

Congratulations on your purchase of your Van Raam tricycle. This bike is produced with utmost care. To guarantee the quality as much as possible Van Raam produces the cycles according to the ISO 9001:2015 quality standards. Van Raam has been certified by DNV GL Business Assurance B.V.

You will especially enjoy your Van Raam bike when the bike is adjusted to your specifications and when the instructions in the user manual are followed. Pay special attention on the service intervals who specified in the manual of the bike.

To claim warranty and service you should always fill out this form, at least at delivery and service. This signed form declares that the end user had an instruction on the operation of the tricycle, that the tricycle is adjusted to the specifications of the end user and that the user manual is received.

Fill out when the tricycle is delivered

Type Van Raam tricycle:	
Frame number:	
Key number:	
Delivered to:	
By dealer:	
Place:	
Date:	
Signature user bike:	Signature dealer:
When available, stamp dealer:	